



The benefits of using Autodesk Civil 3D



Executive summary

This study explores 10 typical workflows common to civil infrastructure projects. Designed by Autodesk and commissioned to an independent consultant this study looks at direct comparisons of the time, effort, and accuracy of each specific task using Autodesk® Civil 3D® versus the same tasks using base Autodesk® AutoCAD®.

This study found the same tasks were completed 95% faster when using Civil 3D, a direct time savings of 43 hours, 40 minutes through the course of the project. An increase in accuracy and precision were also seen in most tasks, reducing the potential for errors and rework. It is impossible to quantify possible rework amounts, but where typical errors could be avoided these were captured in the study details.

There were several tasks that the AutoCAD process was technically faster. In these cases, the Civil 3D process will, in the long-term, end up being more efficient due to the dynamic updating ability of the Civil 3D object data. Finally, there were also several tasks that were simply not realistic to perform using AutoCAD – these are noted in this study and the steps to perform these tasks using Civil 3D outlined.

Key findings



Gained 95%

Overall productivity gain (43 hours 40 minutes) when using Civil 3D versus base AutoCAD to complete tasks throughout the course of a project in this study.



Accuracy improvements

Due to reduced estimation of locations, and the automation of tasks and the precision built into the tools in Civil 3D.

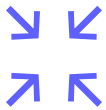

Risk reduction

Tasks undertaken using Civil 3D decreased user-entered data, greatly minimizing errors.

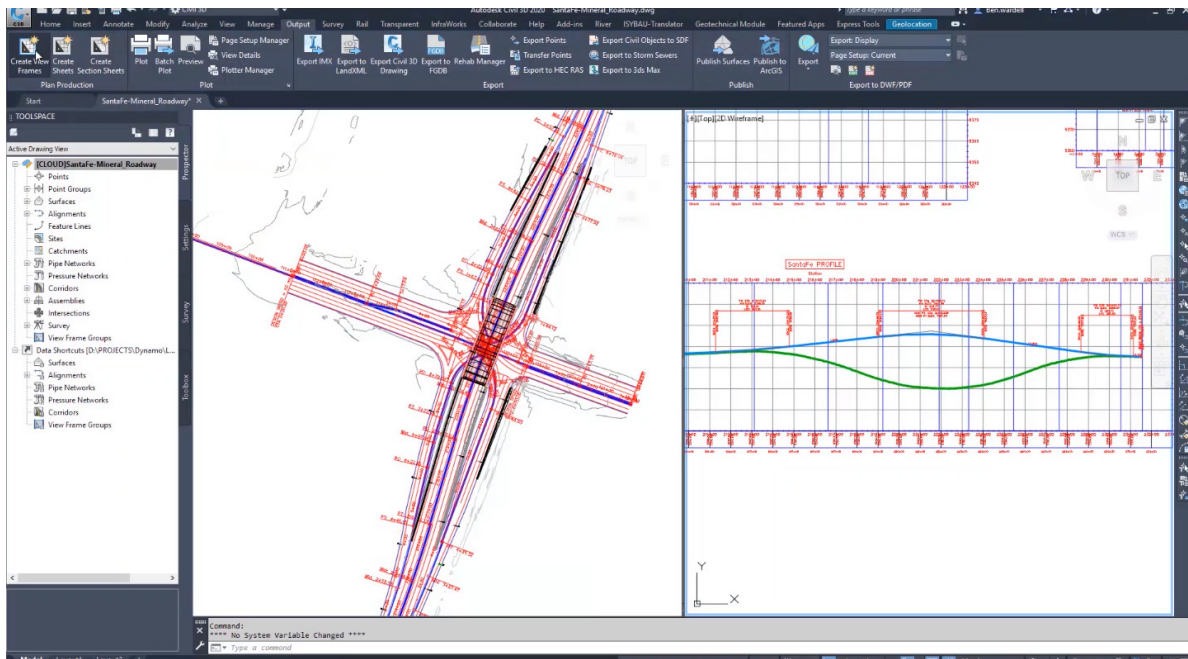

The study

This study looks at 10 general civil design workflows. These workflows are across infrastructure projects but may not represent the needs of every project. Each of these workflows are divided into between 4 and 8 typical tasks and are directly compared between how a user would generally complete the tasks with Autodesk Civil 3D versus Autodesk AutoCAD.

10 civil design workflows studied:

1. Survey, Surface Creation, and Surface Analysis
2. Parcel Design
3. Alignments & Profiles
4. Piping and Drainage Design
5. Grading
6. Corridor Modelling
7. Drawing Production
8. Quantity Takeoff
9. Schedules Production
10. Design Review and Coordination

Throughout this report, each of these workflows will be designated to be associated with specific civil design capabilities. The definitions of those capabilities are at the end of the study.

*The performance results in this paper were achieved by one expert-level user using both AutoCAD and Civil 3D. This user conducted the comparative tests on the same sample civil project data on the same project. The steps involved in each task are listed as a representation for context and may not include every pick and click.

Survey, surface creation, and surface analysis

Prior to detailed grading of the site, areas of the site need to be graded to even out the site pad and create appropriate general drainage. The site was graded at not more than 4:1 slope, with tie-in grading to the pad at not steeper than 2:1 slope. Grading near where the building and parking would later be designed was limited to 2% grading.

This workflow includes the following tasks:

1. Topo survey import from instrument (using FBK format file)
2. Surface and contour creation
3. GIS integration
4. Spot level and gradient labeling
5. Quick section

Design capabilities enhanced

- Site Model Authoring
- Existing Conditions Modeling
- Reality Capture
- Geotechnical Model Authoring

Data size & scope

- 708,000 ft² survey area
- 1,567 points
- Size of file containing surface: 1.3 MB



Design task 1

Topo and survey report

Importing topographic and survey data into a project is the first step towards a more accurate project. Data gathered in the field will accurately represent surface elevations. This data will also include locations of objects in the project area such as trees, utility locations, and many others important to designers. It is typical for survey data to be provided in a format that reflects northing, easting, elevation, and descriptions of individual points. This data needs to be recreated in the project files as the existing conditions on which the proposed design will be created. In this study, the import of a Fieldbook file (.FBK) as received from a surveyor was used.

Steps in AutoCAD

1. Translate surveyor provided FBK (Fieldbook file) into CSV for editing.
2. Edit CSV file including removing unformatted text and columnize data.
3. Convert columns to formatted POINT command entry.
4. Paste all data rows into AutoCAD's command line to create points.

Steps in Civil 3D

1. Create survey database for project, including coordinate system assignment.
2. Import surveyor provided FBK (Fieldbook file) into survey database and design file.

Findings

- 80% time savings when performing this task using Civil 3D versus base AutoCAD.
- Having the survey database provides benefits beyond the ease of use. These benefits include protection of data, inclusion of field captured linework, and point data being available to multiple design files.

Design task 2

Surface and contour creation

A surface is created from lines drawn between survey-collected points at northing, easting, and elevations. These lines will create an irregular network of triangles that represent surface faces, known as a Triangular Irregular Network (TIN) surface. These lines are then used to interpolate contour elevations. This process requires finding the elevation at each end of a TIN line, then estimating where along the line a contour line will cross. The AutoCAD method does have the option of moving a point object along the line to increase accuracy in the elevation location. This process is time-consuming and awkward, so a balance of accuracy versus time needs to be met. For this task, accuracy was acceptable at 0.02' (0.69 cm) from the selected elevation. The Civil 3D process requires less user input, therefore, has a reduced chance of user input errors.

Steps in AutoCAD

1. Draw lines between each point object to create the surface TIN.
2. Find contour elevation crossing locations on each TIN line.

Steps in Civil 3D

1. Create a point group of points that will be used to define the surface TIN.
2. Create a surface object.
3. In the Toolspace add the point group to the surface definition.
4. Set the surface style to the contour interval that is needed.

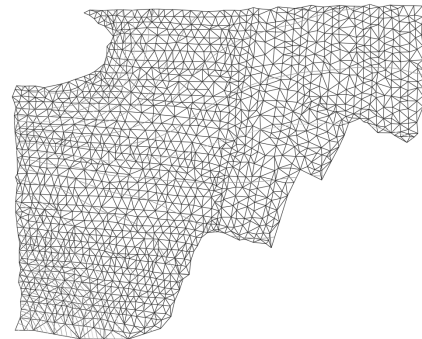
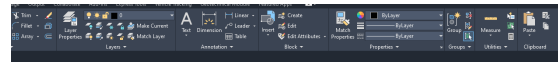

TIN surface in AutoCAD

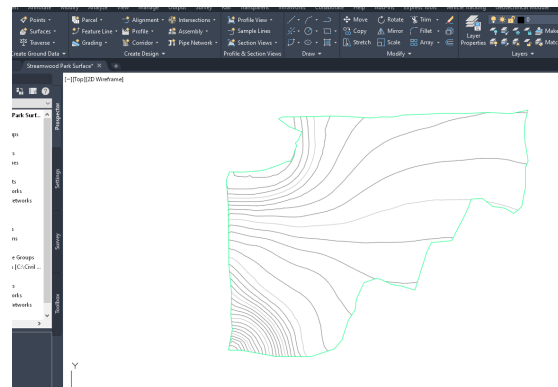

Surface displaying contours in Civil 3D

Findings

- 99.5% time savings using Civil 3D.
- The estimation of where the contour lines cross the TIN lines creates inherent inaccuracies. While these are close enough to not be noticed in most cases, other areas could be more greatly affected. Civil 3D finds the contour elevations much more accurately and quickly.
- In a later stage it was discovered that some lines (22 in (55.88 cm) this project) from the AutoCAD process were missing elevation data due to user error. These areas had to be fixed which added an 1-1/2 hours to the triangulation process in AutoCAD.

“The Civil 3D process requires less user input, therefore, has a reduced chance of user input errors.”

Design task 3

GIS Integration

Many projects will have Geographic Information Systems (GIS) data available for objects in the relative area of the project. This data may include utility information, municipality boundaries, road and rail information, among many others. Generally, survey provided data is more accurate, but GIS data can provide additional attribute data as well as graphics in larger areas surrounding the project.

Steps in AutoCAD

1. Request GIS information in DWG or DWF format.
2. Insert that file into your project as an XREF.

Steps in Civil 3D

1. Start the Autodesk Connector for GIS
2. Identify geographic location for data
3. Search for data available in the geographic area
4. Assign which Civil 3D objects represent imported data
5. Add data to Civil 3D design file

Findings

- AutoCAD does not import file formats that are usually provided from GIS sources. This data would need to be requested in DWG or DWF format for import into an AutoCAD project file. This work would need to be done by your GIS source provider. However, many providers will not provide data in anything other than what they output.
- When simply XREFing the GIS data into the file there is no object data related to the linework. This prevents access of that data during the course of the project.

Design task 4

Spot level and gradient labeling

It is common to place elevation labels and slope labels over the surface at key locations. Spot elevations will read the elevation at the immediate location of the label. Slope labels read the slope of the surface at the location, and generally indicate direction of the slope. This slope may be the natural slope of the ground, or the slope in the direction that is selected.

Steps in AutoCAD

SPOT ELEVATION

- Turn on Nearest OSNAP.
- Draw a construction line from one TIN line to another (or between contour lines).
- Start the POINT command and Nearest OSNAP location for label.
- Delete the construction line.
- Create MTEXT and Insert Field.
- Set field to Object, select the point, set to Position, turn on Z (turn off X & Y).

SLOPE

- Turn on Nearest OSNAP.
- Draw a construction line from one TIN line to another (or between contour lines).
- Open the Properties palette to find construction line's delta Z and length.
- Calculate delta Z / Length.
- Draw arrow to indicate direction.
- Create MTEXT and type in slope text.

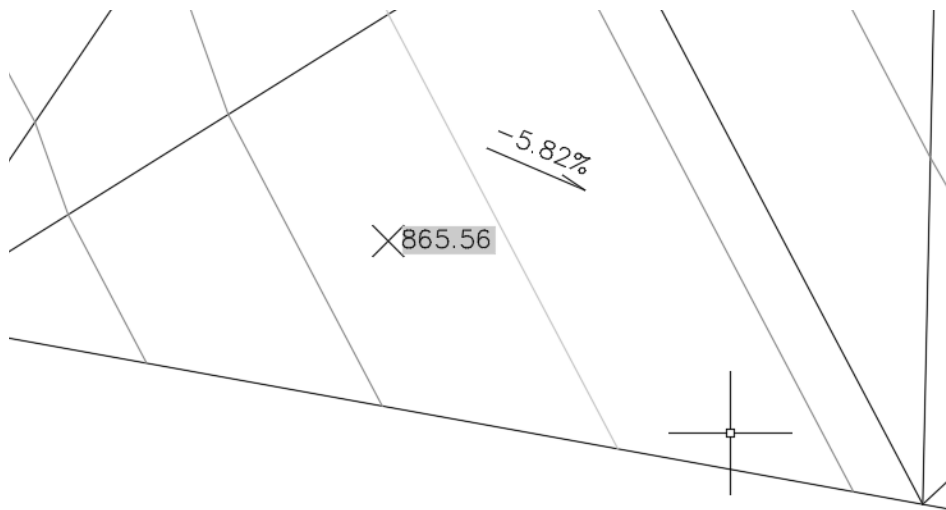

Spot elevation and slopes labels in AutoCAD

Steps in Civil 3D

1. Annotate tab > Add Labels > Surfaces > Add Surface Labels.
2. Set to Spot Elevation, set the proper style, and Add.
3. Place labels on surface as needed.
4. Set to Slope, set the proper style, and Add.
5. Select One-point or Two-point methods for label placement.
6. Place labels on surface as needed.

“Civil 3D labels are dynamic to changing surface conditions.”

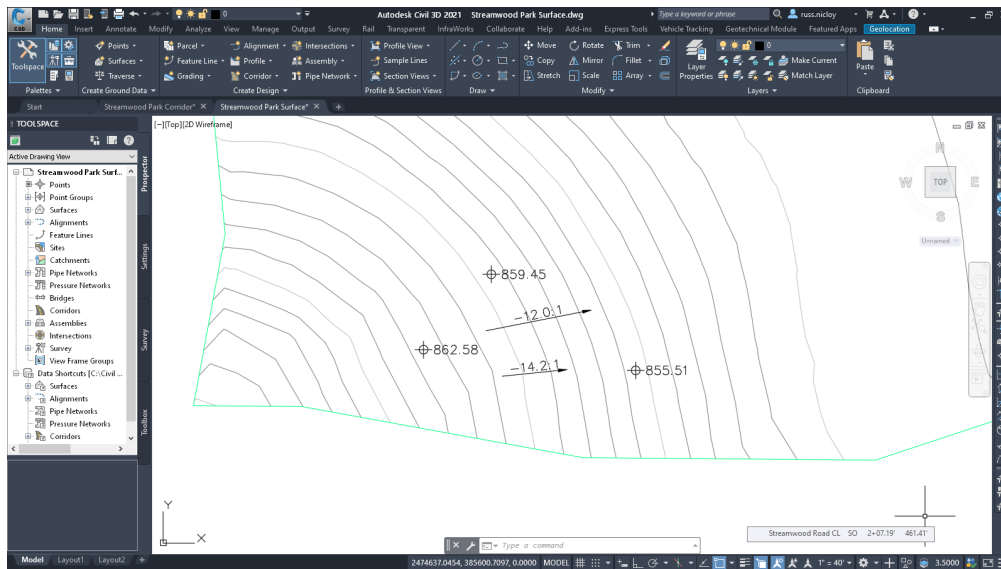

Spot elevations and slope labels in Civil 3D

Findings

- 92% time savings using Civil 3D.
- The AutoCAD method is not dynamic. Changes to the surface, or the need to move a label will require creating a new label (potentially many) and deleting the old label(s).
- Civil 3D labels are dynamic to changing surface conditions. This leads to faster workflows and better-quality labeling as the project progresses. This also reduces the chance of errors or overlooked changes.

Design task 5

Quick Section

A “quick section” is a very localized profile view to check surface conditions. It can be particularly useful for quick analysis of areas or for troubleshooting surface issues. Generally, profiles are created from alignments, but quick profiles are meant to be temporary, and do not require use of a full alignment to be created.

Steps in AutoCAD

1. Draw a line where the quick profile sample should be taken from.
2. Create a profile view grid, estimating the length of the sample line and how much elevation will be needed. Remember to include vertical exaggeration.
3. Create POINT on each triangle edge where that line crosses the edge.
4. Measure distance from point to point.
5. In profile view recreate the line between points using distance and elevations between points (remember vertical exaggeration of grid).

Steps in Civil 3D

1. Draw an AutoCAD Line or Polyline at the location the quick profile should sample from.
2. Create a Quick Profile and select that Line or Polyline.
3. Select the grid style and assign profile styles to the sampled surfaces.
4. Place the profile grid view in the drawing.

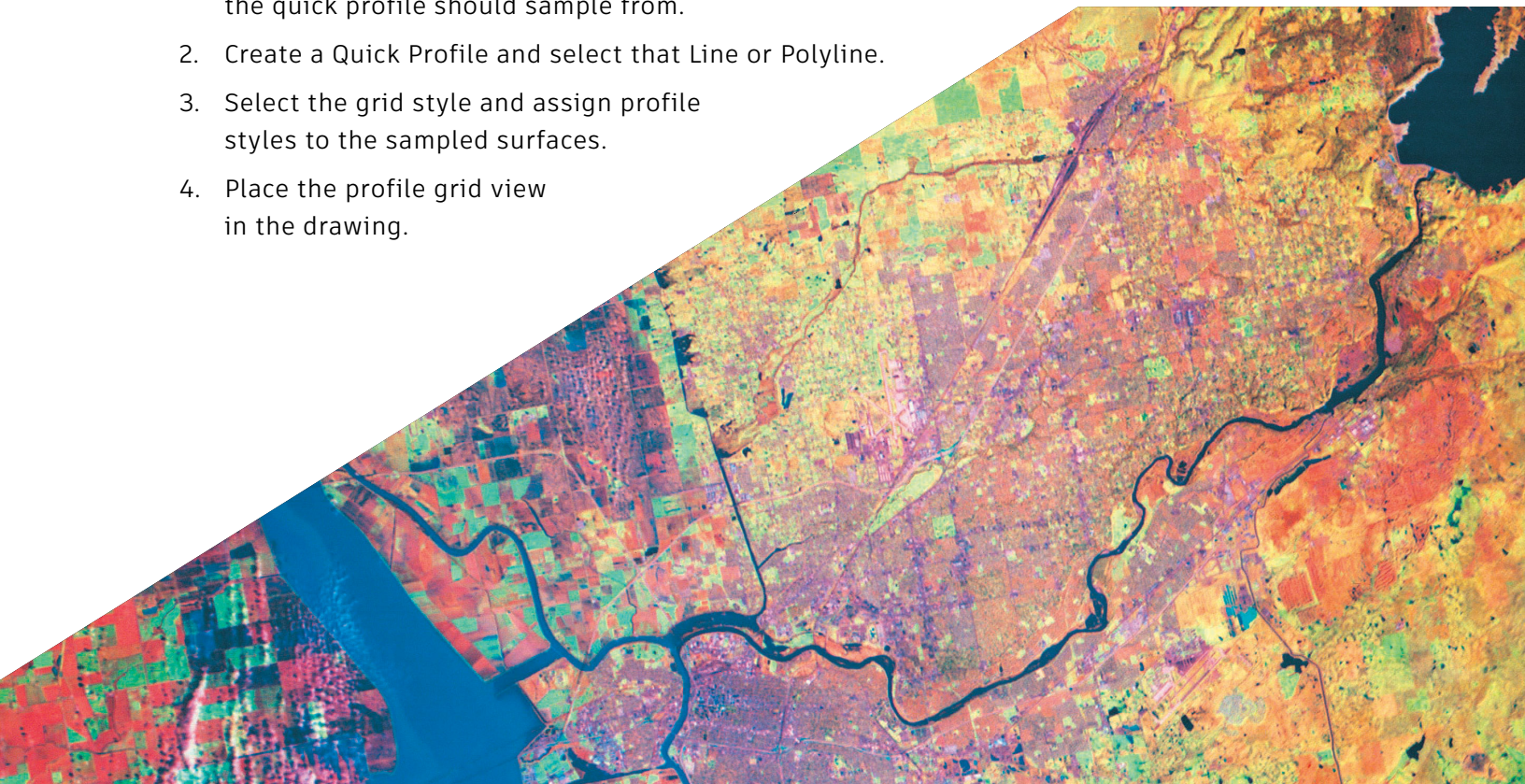

Findings

- 97% time savings when using Civil 3D over base AutoCAD.
- The Civil 3D Quick Profile is fully dynamic. As the line or polyline is moved it changes the data displaying in the profile view.
- The Civil 3D Quick Profile is intended to be temporary and will disappear if the line/polyline is deleted, or when you close the file.
- The AutoCAD process of estimating the elevation locations has the same inherent inaccuracies found in the AutoCAD contour creation process.

Productivity gains

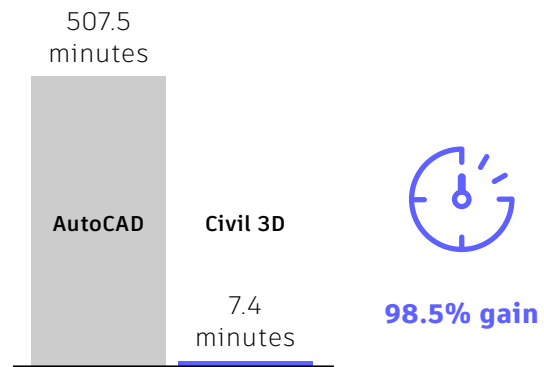

Tasks	AutoCAD	Civil 3D	Time savings using Civil 3D
1. Topo and survey import	15	3	80%
2. Surface and contour creation	480	2.5	99.5%
3. GIS integration	1.5	1.5	0.0%
4. Spot level and gradient labeling	1	0.083	91.7%
5. Quick selection	10	0.333	96.7%

(Figures shown in minutes)

Parcel design

This workflow includes the following tasks:

1. Parcel creation
2. Input existing parcels
3. Parcel design
4. Reporting
5. Takes

Design capabilities enhanced

- Site Model Authoring

Data size & scope

- 624,169 ft² overall parcel area
- 19 single-residence parcels, 2 outlots

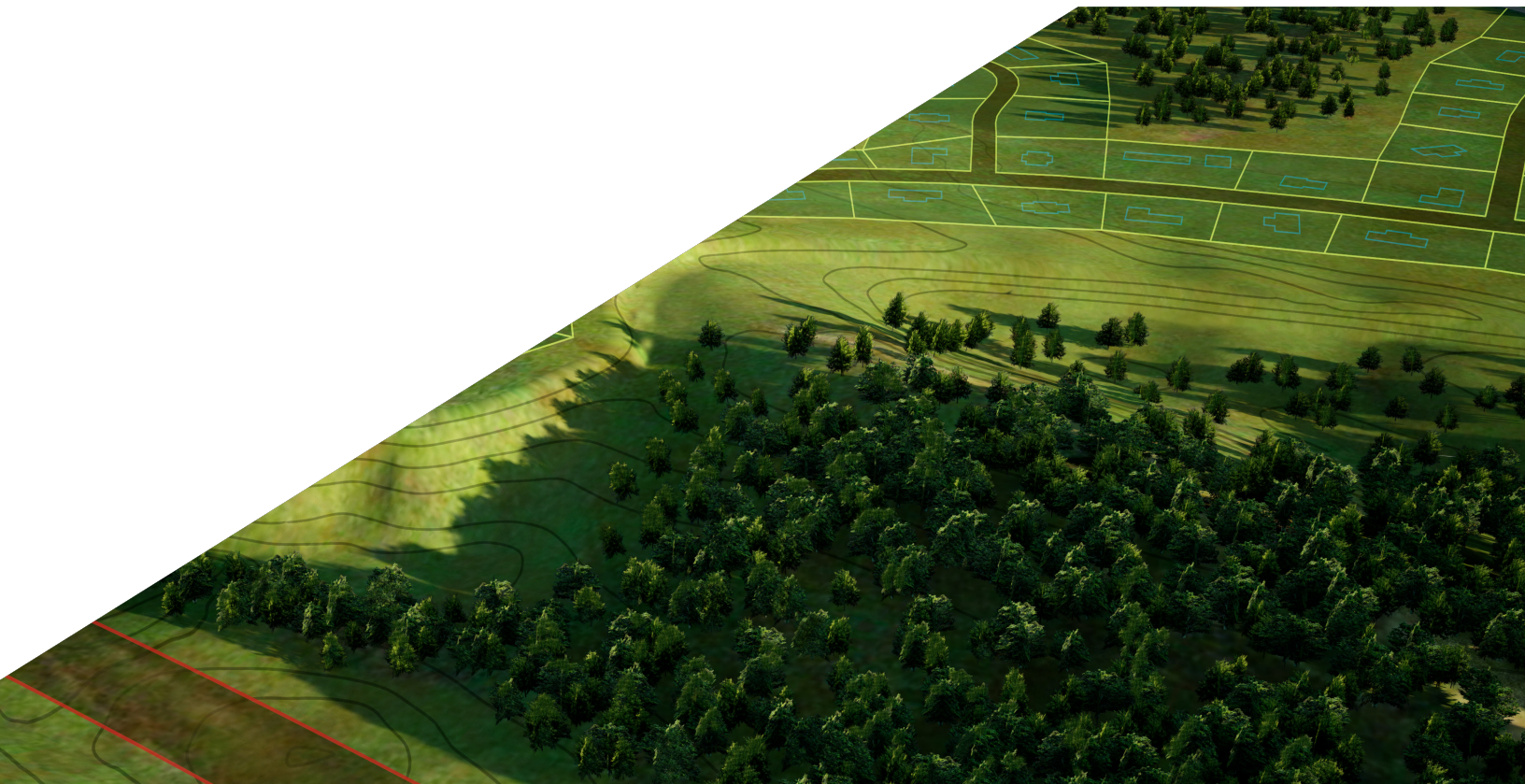

Design task 1

Parcel creation

Parcels represent the legal boundaries of subdivided land. Most projects will have some sort of existing parcel information that will be adjacent or divided by the project. The legal description of a parcel can be created in AutoCAD by adjusting the bearing information to AutoCAD directional format, or in Civil 3D by entering the bearing and distance data. The parcels created in this phase are the larger project areas and will likely be divided as the project progresses.

Steps in AutoCAD

1. Set the angular UNITS for the file to Surveyor Units.
2. Turn on DYNINPUT to aid proper entry option.
3. Start Polyline command typing in the point of beginning of the parcel line.
4. Type in direction as (example: 90d 32' 30") Tab to enter distance.



Parcels created in AutoCAD

Steps in Civil 3D

1. Start Polyline command typing in the point of beginning of the parcel line.
2. Use the Bearing and Distance Transparent Command.
3. Enter quadrant, bearing (example: 89.1230), and distance.

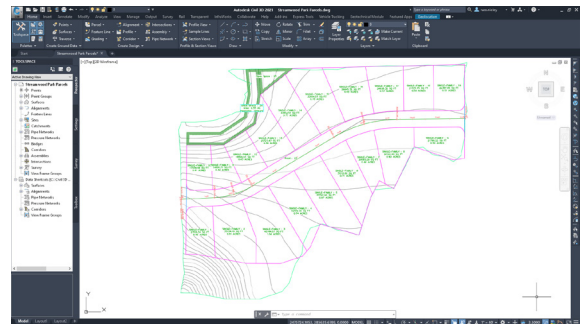

Parcels created in Civil 3D

Findings

- 82% time savings when using Civil 3D.
- Most of the time taken using AutoCAD was for translating the bearings into the AutoCAD directional format. This is slightly different than traditional bearing format.

Design task 2

Input existing parcels

Including existing parcel data that is adjacent to the project proposed parcels can be helpful during the parcel creation process. This data may not need to be editable so externally referenced for ease of access.

Steps in AutoCAD and Civil 3D

1. Run the Attach XREF command.
2. Browse and select the file to XREF.
3. Set location, rotation, and scale settings.

Findings

- This took the same amount of time for both functions since they both used XREF to reference the existing parcel document.
- This data would remain an XREF unless the individual lines and data are needed in the file. Both Civil 3D and AutoCAD would use the same insert functions if this were required.

Design task 3

Parcel design

To design the proposed parcels certain parameters would need to be met, including the frontage length and area of each parcel. Starting with the overall parcel these parameters can be used to guide the parcel subdivision into smaller parcels.

Steps in AutoCAD

1. Measure frontages by placing points at correct distances.
2. Draw a polyline around parcel and close it (repeat for each parcel).
3. Check the properties for the closed polyline for area and perimeter information.
4. Compute acres from sq ft.

Steps in Civil 3D

1. Set the parcel parameters, including parcel area, frontage, offsets, in the Parcel layout tools, Slide Line Create tool.
2. Identify frontage of roadway.
3. Accept or reject parcel layouts.

Findings

- 75% efficiency gain when using Civil 3D.
- The Civil 3D tools allow for confirmation of lot size prior to creation. Edits to the size of the parcels are easy after creation, with recalculation of parcel areas being automatic.

Design task 4

Parcel design

Parcel data regularly needs to be reported in a format that a graphic representation alone is not appropriate. Tables can be created in the file to centralize the parcel data for easier review. Reports can take this data outside the drawing file for inclusion in other project documentation.

Steps in AutoCAD

TABLES

1. Create AutoCAD table.
2. Add table name, and data column headers text.
3. Insert text with object data fields attached to each closed polyline parcel shape.
4. Enter manual text to fields that are not supported by object data fields, or as preferred. Compute acres from sq ft.

REPORTS

1. Use company report docx document to start report
2. Type in parcel data per field per report standards.

Steps in Civil 3D

TABLES

1. Add parcel area tables.
2. Identify parcels to include in table.
3. Sort table by parcel number rows and make adjustments to field precision.

REPORTS

1. Use company report docx document to start report
2. Type in parcel data per field per report standards.

Findings

- 64% gain in efficiency with Civil 3D.
- The AutoCAD reports require manual creation of fields and lend themselves to user error in retyping the data needed.
- Reports in AutoCAD and Civil 3D are both not dynamic to the parcels involved. While in both cases the reports will have to be recreated, the Civil 3D report creation process is much faster and easier to complete.
- In AutoCAD fields connected to objects and report fields update automatically if changes occur to the parcels. The process of adding these fields is longer than the Civil 3D table creation, but aid in dynamic editing later.

Design task 5 Takes

After the parcels are defined some parcel data may need to be “purchased” from those parcels for other needs, such as rights-of-way, easements, or public use. This data removes parcel area from affected parcels and transfers it to another parcel.

Steps in AutoCAD

1. Define border of taken parcels with a polyline.
2. Redefine previously proposed parcels closed polyline shapes.

Steps in Civil 3D

1. Creation of a parcel that defines the taken parcel area.

Findings

- 42.9% Faster when conducted using Civil 3D.
- Parcels taken from an AutoCAD defined parcel will need to have only the affected area removed from the area calculation of each parcel.
- AutoCAD parcels that are redefined from the original proposed to the new smaller parcel can update object data fields in text fields if they were used.
- Civil 3D parcel creation that overlaps another parcel will automatically take the parcel area and give it to the new parcel takings area.

Productivity gains

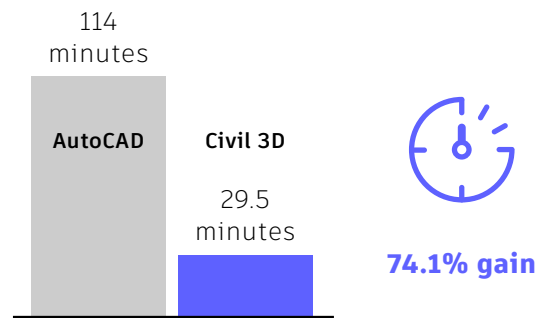

Tasks	AutoCAD	Civil 3D	Time savings using Civil 3D
1. Parcel creation	45	8	82.2%
2. Input existing parcels	0.5	0.5	0.0%
3. Parcel design	40	10	75.0%
4. Reporting	25	9	64.0%
5. Takes	3.5	2	42.9%

(Figures shown in minutes)

Alignments and profiles

This workflow includes the following tasks:

1. Horizontal and vertical best fit
2. Horizontal layout – tangents and curves
3. Alignment profile/section
4. Alignment labelling with chainage
5. Vertical layout
6. Intersection design, roundabouts, cul-de-sacs

Design capabilities enhanced

- Road and Highway Model Authoring
- Rail Track Model Authoring

Data size & scope

- 1,200 feet of alignment
- 2 horizontal curves (325 feet and 500 feet radius)
- 3 tangent lines
- 3 vertical curves



Design task 1

Horizontal and vertical best fit

The Best Fit construction of an alignment comes from the difficulty of survey crew in the field identifying the true centerline of a road. Since their shots are a best estimate positions true tangent and curve definition are difficult if not impossible. The Best Fit option is the only reasonable way to recreate the existing conditions in the design files.

! Because the process to perform this task in AutoCAD is completely dependent on the user's best judgement and inherently error prone, it is unrealistic to conduct this task in AutoCAD and expect any acceptable level of accuracy. As such, a study that compares performing this task in AutoCAD vs. Civil 3D was not conducted. It is important to note that while the Civil 3D process is much more accurate, user error in assigning the curve creation parameters could introduce inaccuracies to the result.

Steps in Civil 3D

1. Create a point group that identifies the existing alignment centerline points from the survey data.
2. Use the Alignment > Best Fit command.
3. Identify which point group includes the surveyed centerline points.
4. Check the regression graph for precision. Complete the alignment object.



Design task 2

Horizontal layout

The horizontal layout of the design creates the path of the project. This horizontal definition can be used as the baseline for the design as well as an index for profiles, sections, and other geometric definition in the project.

Steps in AutoCAD

1. Draw line from POB to distance at bearing. Repeat for the other tangents in the alignment.
2. Draw a circle with Tan-Tan-Radius at each PI location.
3. Trim polylines and circles until tangent arcs.
4. Polyline Edit and Join the segments and arcs together.

Steps in Civil 3D

1. Start alignment command and place first point at POB.
2. Use transparent command Bearing Distance to place the tangents at proper locations. The curves will be placed as these are defined.

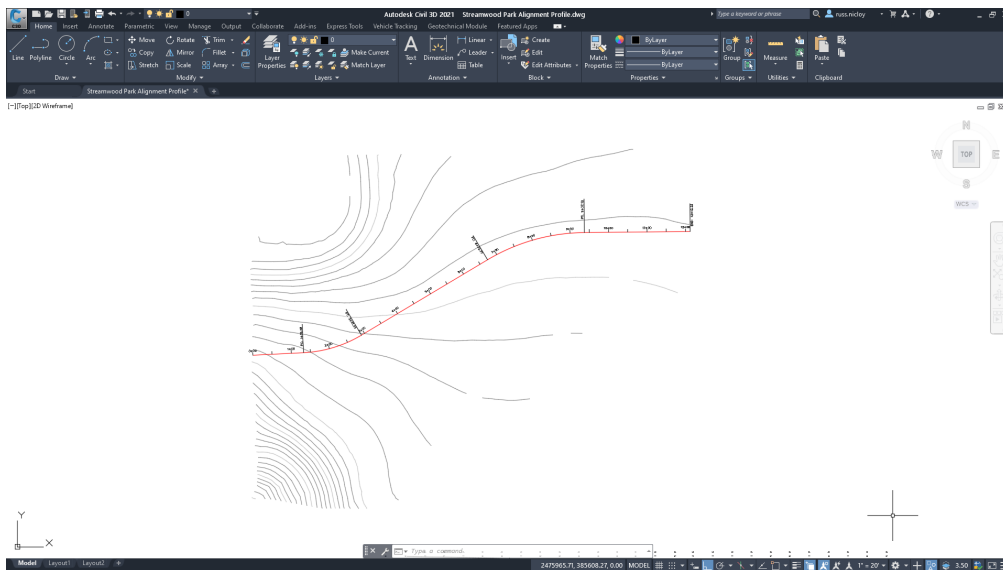

Horizontal layout in Civil 3D

Findings

- 72.7% Efficiency gain using Civil 3D.
- Performing this task with Civil 3D did use the Tangent-Tangent (with Curves), so the curves were automatically placed as the design was created.
- If spirals are required in the design, then AutoCAD wouldn't be able to complete this task at all without Civil 3D or alternate add-in software.

Design task 3

Alignment existing ground profile/section

Profile and section views display the elevations of surfaces along the horizontal layout. It is typical for these views to include some vertical exaggeration so smaller details can be observed.

Steps in AutoCAD

1. Create the profile view grid by drawing lines and offsetting them at 50' (15.24 m) locations for the length of the horizontal layout and for the height of the needed elevations.
2. At the horizontal layout place point elements at each surface triangle intersection to capture the elevation at these locations.
3. Measure the distance between the first point to the second point and measure the difference in elevation between the points.
4. Place a line in the profile grid from the first station at elevation to the next point's distance and elevation.
5. Repeat for each surface triangle the horizontal layout crosses.
6. Cleanup distance and elevation marks in the profile grid to create the vertical profile.
7. For sections, create sample lines perpendicular across alignment at 100' (30.48 m) stations. These sample lines should be 100' (30.48 m) in both directions (total 200' (60.96 m)).
8. Repeat profile grid creation process for each sample line, 200' (60.96 m) long and with elevations appropriate for each cross-section elevation at 10 vertical scale.
9. Repeat the sampling steps from the alignment profile for each 100' (30.48 m) sample line and place them in appropriate section views.

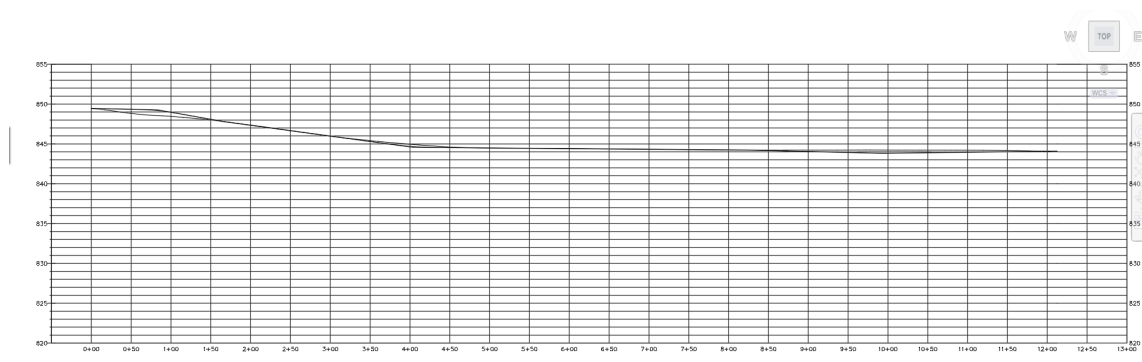

Existing Profile in AutoCAD

Steps in Civil 3D

1. Create surface profile using the alignment and surface.
2. Create profile view to display the surface profile.
3. Create a proposed profile inside the profile grid view.

Findings

- 99.9% time savings using Civil 3D.
- The AutoCAD process is inherently inaccurate and imprecise.
- The AutoCAD process depends heavily on user input. This provides the potential for errors that may compound as the data is entered.



Design task 4

Alignment labeling with chainage

The horizontal layout of the design creates the path of the project. This horizontal definition can be used as the baseline for the design as well as an index for profiles, sections, and other geometric definition in the project.

Steps in AutoCAD

1. Place a tick line perpendicular to alignment. Use path array to place along the alignment at 50'(15.24 m) intervals.
2. Place text to read stations, copy, place, and rotate for each station tick mark.
3. Place lines perpendicular to alignment at begin and end of curve stations.
4. Measure distance to BC and EC and place station text as MTEXT.

Steps in Civil 3D

1. The labeling process occurs immediately with the creation of the alignment.

Findings

- 100% productivity gain with using Civil 3D.
- Civil 3D alignments label automatically when the alignment geometry is completed.
- Using Civil 3D, there was no work or time required in order to achieve the same labelling as was needed when creating them using AutoCAD.

Design task 5

Vertical layout

Creation of the vertical layout of the design identifies the elevation of the design baseline along the project. While the distance matches the alignment stationing, the vertical design is displayed with a vertical exaggeration to make smaller vertical details more visible.

! Performing this task using AutoCAD would require creating circular or parabolic arcs in a 10X exaggeration which is not realistic to be completed accurately. It was impractical to conduct this comparison.

Steps in Civil 3D

1. Using the Profile Creation Tools create the beginning tangent slope and the ending tangent slope.
2. Create Tangents between these two tangents to identify slopes along the project.
3. Use the Free Curve tools to add a curve that is tangent to each vertical tangent.

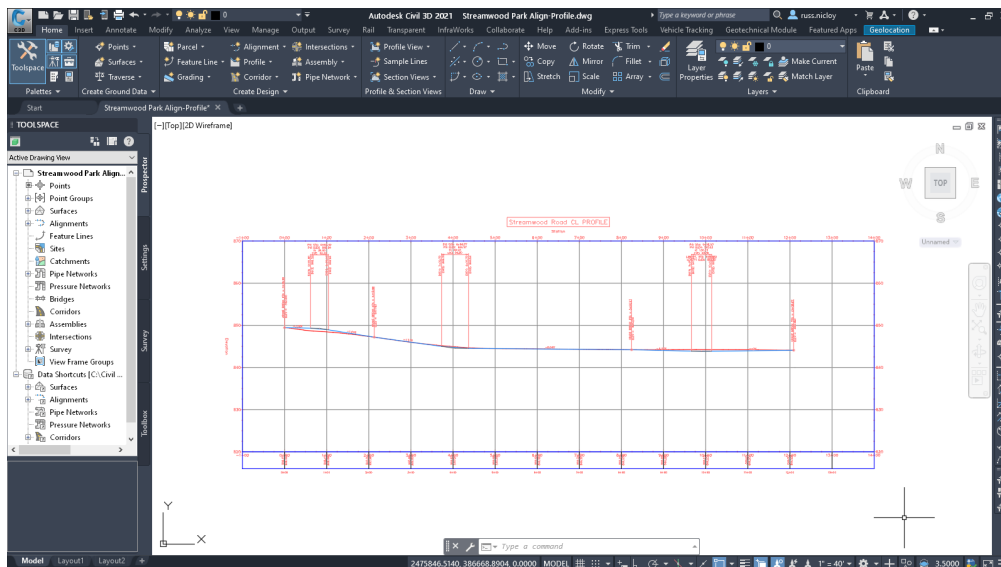

Proposed profile in Civil 3D

Design task 6

Intersection design/ roundabouts/cul-de-sacs

Laying out an intersection, cul de sac, or roundabout is the first step in fully developing these common designs of a project. Civil 3D has tools that address the more user-intensive steps of the design, while the AutoCAD process is based on offsets and trimming to achieve the layout. Laying these designs out shows where there may be space issues with the area being developed, and may encourage an alternate location in the site, or alternative design. This process will focus on the horizontal layout of each of these. A full design including vertical dimensions would be similarly extensive.

Steps in AutoCAD

INTERSECTION

1. Where the intersection is to be designed offset the secondary road alignment to find the road edges (as well as the curb and gutter and terrace).
2. Draw curb return circles, tangent to the road edges. Trim to match.
3. Trim and clear the lines that continue through the intersection.

CUL-DE-SAC

1. Create cul de sac bulb.
2. Offset road CL to find road edge.
3. Create tangent circles from road offset to cul de sac bulb. Trim
4. Create joined polyline

ROUNDABOUT

1. Place the roundabout inner circle at the intersection.
2. Offset to find apron edge and lane edge (also curb and gutter and terrace).
3. Create offsets from secondary road to road edge (also curb and gutter and terrace).
4. Create offset for each road arm widening at the roundabout.
5. Create the outline of the splitter island edge and curb.
6. Create circles tangent to road edges. Trim.
7. Trim and clean all lines through the roundabout.

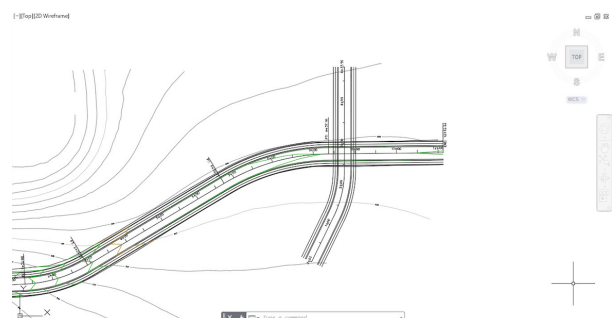

Laying out an intersection in AutoCAD.

Steps in Civil 3D

INTERSECTION

1. With two alignments crossing, start the Intersection command.
2. Select the main road alignment.
3. Set the Crown-to-Crown match option.
4. Leave the curb return offset settings and finish the intersection wizard.
5. Adjust the length of the offset alignments in all four directions of the intersection.

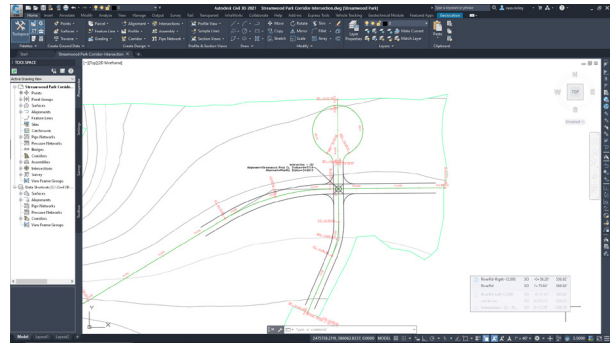

Intersection and Cul de sac in Civil 3D

CUL-DE-SAC

1. Create cul de sac bulb.
2. Offset road CL to find road edge.
3. Create tangent circles from road offset to cul de sac bulb. Trim.
4. Create joined polyline.
5. Create Alignment from Object and select the polyline.

ROUNDAABOUT

1. With two alignments crossing, start the Intersection > Roundabout command.
2. Assign the roundabout data file to use.
3. Identify the center point of the roundabout.
4. Identify each incoming alignment arm.
5. Check measurements and data on the wizard pages.
6. Finish the roundabout wizard to complete the design.

Findings

- 86.1% productivity efficiency gain.
- These steps are for the horizontal layout of these designs.
- The tested process did NOT include revisions and corrections to the layout of the three design areas. Revisions and corrections are inevitable during a process such as this. These revisions would impact the performance to conduct this task whether AutoCAD or Civil 3D were utilized to complete the process.
- However, when conducting this task using AutoCAD, the design processes are not dynamically linked and the tools to aid in the creation and computation of design elements are not available. So, while revisions would affect both processes, it would have a greater negative effect to the AutoCAD user. Changes would not be updates but would be complete recreations of the design elements.

Productivity gains

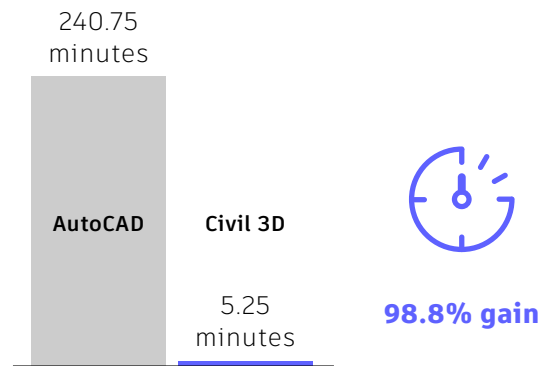

Tasks	AutoCAD	Civil 3D	Time savings using Civil 3D
1. Horizontal and vertical best fit	0	0	0.0%
2. Horizontal layout (tangents & curves)	5.5	1.5	72.7%
3. Alignment profile/section	195	0.25	99.9%
4. Alignment labeling with chainage	15	0	100%
5. Vertical layout	0	0	0.0%
6. Intersection, roundabout, & cul-de-sac layout	25.25	3.5	86.1%

(Figures shown in minutes)

Piping and drainage design

This workflow includes the following tasks:

1. Surface analysis for falls and catchment areas
2. Network layout (horizontal and vertical)
3. Crossing pipes clash check
4. Drainage profile
5. Drawing production (plans/profiles)
6. Manhole schedule
7. Automation of labeling

Design capabilities enhanced

- Drainage Model Authoring
- Utilities Design
- Water Distribution Model Authoring

Data size & scope

- 16 manholes/inlets
- 1,300 feet of storm pipe,
200 feet of culvert
- 15 pipes and 3 culverts



Design task 1

Surface analysis for falls and catchment areas

Before creating the drainage system design it is important to define where natural drainage will occur, both before and after the project construction. Finding where water will run from a start point (example: a raindrop hitting the surface) and then identifying where water will gather are both critical to this surface analysis.

Steps in AutoCAD

1. Select a point to begin the raindrop or catchment analysis.
2. For drainage draw a polyline from the chosen point perpendicular (Perpendicular OSNAP) to the nearest contour line lower in elevation.
3. For catchment areas draw a polyline from the chosen point perpendicular (Perpendicular OSNAP) to the nearest contour line lower in elevation.
4. Continue drawing perpendicular to the next contour until a low or high point is reached.

Steps in Civil 3D

1. Start the waterdrop tool and define the layer it should be placed.
2. Click points to identify where water will run across the surface.
3. Start the catchment area tool.
4. Click points of suspected water concentration to identify water area of the surface will contribute to the water collection.

Findings

- 62.5% efficiency gain using Civil 3D.
- While the time difference between the AutoCAD process and Civil 3D process does not appear significant, this difference will compound with each needed catchment area or contour-based drainage line.
- The AutoCAD process is heavily dependent on user choices as well as the amount of contour data available. Both will likely compound user errors as well as add inherent inaccuracies.

Design task 2

Network layout (horizontal and vertical)

The pipe network needs to be created in the horizontal plan view as well as in the profile view. The horizontal pipe network design will start as a line from start to end with vertex points where the pipe direction changes. Network structure symbols will be placed at each location where the direction changes, or where other pipes join the network. In the vertical design the system will start at the low elevation of drainage, or where it is connected to the outflow of the network and continue upstream to the first structure location. This will ensure the design respects the minimum and maximum slopes of the pipes as well as maintain a minimum depth under the surface grade.

Steps in AutoCAD

HORIZONTAL DESIGN

1. Draw polyline from drainage system from start point with straight segments along alignment to end point connection to the outlet connection to the existing system.
2. Draw polyline locations for inlets draining into the network.
3. Place blocks to represent manholes and inlets at each bend or connection.
4. To calculate depth offset the proposed ground surface to minimum depth.
5. Starting at the low elevation draw a line that represents the crown of pipeline relative to minimum depth line along length of pipe network.
6. Offset pipe crown lines down to find bottom of pipes (include vertical exaggeration).

VERTICAL DESIGN

1. In profile grid place markers at stations of horizontal manhole locations at proposed ground elevations.
2. Draw lines from proposed ground locations down for beginning of manholes.
3. Offset the manhole vertical centerlines to show the width of manhole structures.
7. Trim pipes at manhole edges.
8. Draw bottom of manholes at pipe bottoms where they meet the manholes. Trim manhole and pipelines.
9. Draw manhole rim lines across the top of the manholes at surface elevation.
10. Trim and clean all lines through the roundabout.

Steps in Civil 3D

1. Create storm pipe network.
2. Place manholes starting from low point connection to existing network uphill to the project high point.
3. Place inlets and create pipes back into network.
4. Select a part of the pipe network in plan and choose Draw Parts in Profile View. Select the profile view.
5. In Profile View Properties, Pipe Networks tab make sure the pipes and structures are on and the correct style.

Findings

- 73.9% time savings using Civil 3D.
- In the AutoCAD process, the manholes along the road were placed at the centerline alignment of the road, but the pipes went from structure to structure. This caused those pipes to not follow the alignment directly. While the structures are getting the correct profile depth locations, pipes between structures may deviate from the correct depth. It is likely another alignment and profile will be needed to display the depths of pipes to ensure they are correct. This was not created for this task since it is a project manager's prerogative to accept the estimated pipe depth under the road surface. It is completed in an upcoming task.
- In the Civil 3D process the structures and pipes are similarly placed along the road centerline, but the pipe creation process takes into account the surface elevation above the pipes. While we will still need a second alignment/profile view to see this depth, the placement is correct.

Design task 3

Crossing pipe clash check

Proposed pipes may have been designed in a way that will conflict with other pipes in the area (existing or proposed). Checking for clashing pipes is important prior to construction to prevent changes being needed in the field.

Steps in AutoCAD

1. Create a cross section sample line at locations of suspected pipe clash.
2. Copy a section view grid (or profile view grid) and adjust it to display the section sampled area.
3. Paste the road design cross section in grid at the elevation of the proposed profile at that station.
4. Create pipe locations at section view station based on profile depth.

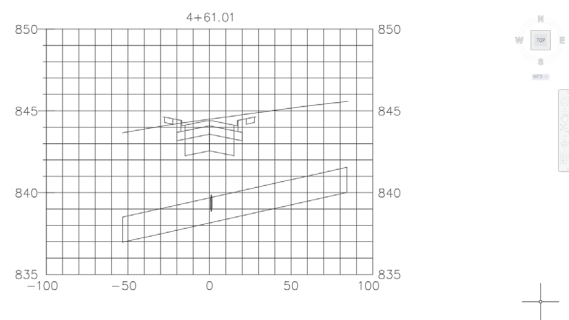

Pipe conflict in AutoCAD

Steps in AutoCAD

1. In the toolspace expand the pipe network to create an interference check.
2. Identify the storm network and the existing culvert system.
3. Pan along the network to find the interference check marker objects.
4. In profile fix any clashing pipe depth.
5. Rerun the interference check to make sure no clashes still exist..

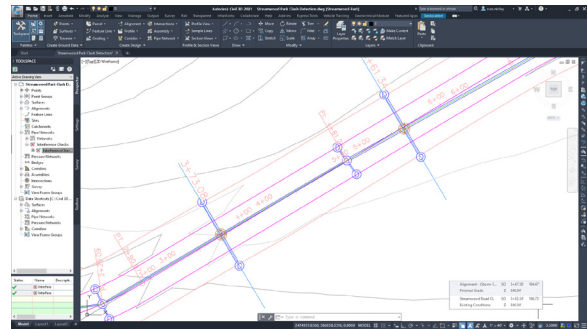

Pipe Interference checks in Civil 3D

Findings

- 91.7% time savings using Civil 3D.
- The AutoCAD process requires the user to know where they are checking for clashing pipe locations. This could result in overlooked clash locations. The Civil 3D process searches out locations along entire pipe networks to ensure no clash locations are missed.
- The AutoCAD process requires a complete cross section view creation which includes user creation of the section data which can lead to introduction of user error. The Civil 3D process finds the clash locations without requiring section or profile views.

Design task 4

Drainage profile

This profile reflects the alignment over the pipes and structures and may deviate from the alignment for the road design. While the profiles would be generally close, having precise location and depth information where the two alignments differ is important to the construction of the pipe network. It also helps identify where issues may appear along the pipe design that the road profile would miss.

Steps in AutoCAD

1. Copy a profile grid from the road profile area. Make sure no object information comes with the grid.
2. Create the existing and proposed profile at the pipe alignment location.
3. In the profile grid place markers at stations of horizontal manhole locations at proposed ground elevations.
4. Draw lines from proposed ground locations down for beginning of manholes.
5. Offset manhole vertical centerlines to width of manholes.
6. To calculate depth offset proposed ground surface to minimum depth.
7. Draw crown of pipeline relative to minimum depth line along length of pipe network.
8. Offset pipe crown lines down to find bottom of pipes (include vertical exaggeration).
9. Trim pipes at manhole edges.
10. Draw bottom of manholes at pipe bottoms where they meet the manholes. Trim manhole and pipelines.
11. Draw manhole rim lines across manhole at surface elevation.

Steps in Civil 3D

1. Select the first upstream structure and choose Create Alignment from Network.
2. Select the last downstream structure.
3. During the alignment creation choose to create Profile and Profile View.
4. Place the profile view near the project.

Findings

- 98.7% productivity gain with using Civil 3D.
- Using AutoCAD, the existing conditions can be added for context, but the design depths will be from the proposed road surface elevation. In this case, only the surface triangles in the lane were needed since the pipes did not cross the lane edge.
- With AutoCAD, due to the user re-entering of the profile data, chances for user error increase the likelihood of error in the profile view and pipe depth locations.
- When conducting this task using AutoCAD, it may become apparent that the pipe depth and slopes might need to be adjusted which means further adjustments to the road alignment profile. This was not considered in this task.

Design task 5

Drawing production (plans & profiles)

Due to sheet size and scale on those sheets the design area is limited to how much will fit on each page. The overall length of the pipe network will be displayed in multiple sheets with specified length per sheet. A profile view will be created to reflect the plan stationing from each sheet's length.

Steps in AutoCAD

1. Create layout tab for the first sheet with a viewport set to the expected scale.
2. Navigate view over the plan location, rotate the view for a better fit.
3. Identify the appropriate length of stationing for this first sheet.
4. Create the number of sheets that will be needed for the entire project length using the first sheet stationing as a guide.
5. Navigate each layout's viewport to cover the project stationing, and rotate view to better fit in the sheet.

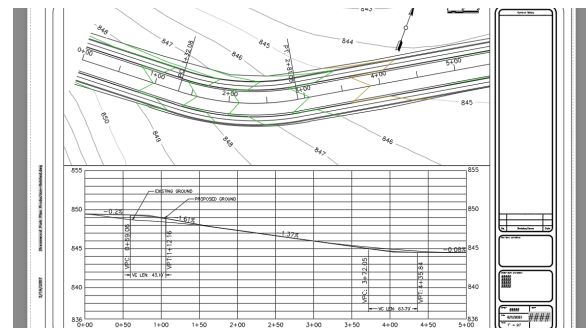

Plan over profile sheet in AutoCAD

6. Copy the overall profile view grid and place one for each sheet to be created.
7. Trim each view to each sheet's station length and move text to properly display the new layout.
8. Create a profile viewport in each sheet and navigate the view over the profile views.

Steps in Civil 3D

1. Use the Create View Frames command to identify station length of each sheet.
2. Use the Create Sheets tool to create the plan and profile sheets needed to cover the network length.

Findings

- 82.8% greater efficiency with Civil 3D.
- This production sheet for the pipe networks is created from the alignment over the pipes and was not the same geometry as the alignment used from the Plan Production sheets of the road design.

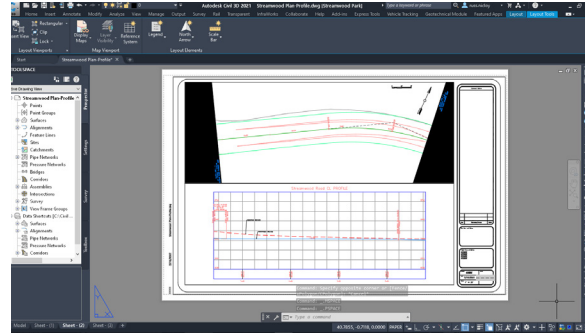

Plan over profile sheet in Civil 3D

Design task 6

Manhole schedule

A table of data for the structures will be placed to communicate location, rim and sump elevations, and related pipes.

Steps in AutoCAD

1. Create an AutoCAD table.
2. Create table column headers for structure number, rim elevation, sump depth, and pipe out invert elevation.
3. Type structure number, rim elevation, sump depth, and pipe out invert information to the table fields.

Steps in Civil 3D

1. Use the Add Structures table tool.
2. Make sure the style is set to sort by column 1.

Findings

- 82.8% gain in efficiency using Civil 3D.
- The AutoCAD process requires user input of depth and elevation data for the structures from the profile view. Depending on grid vertical exaggeration user error could be introduced during this process.

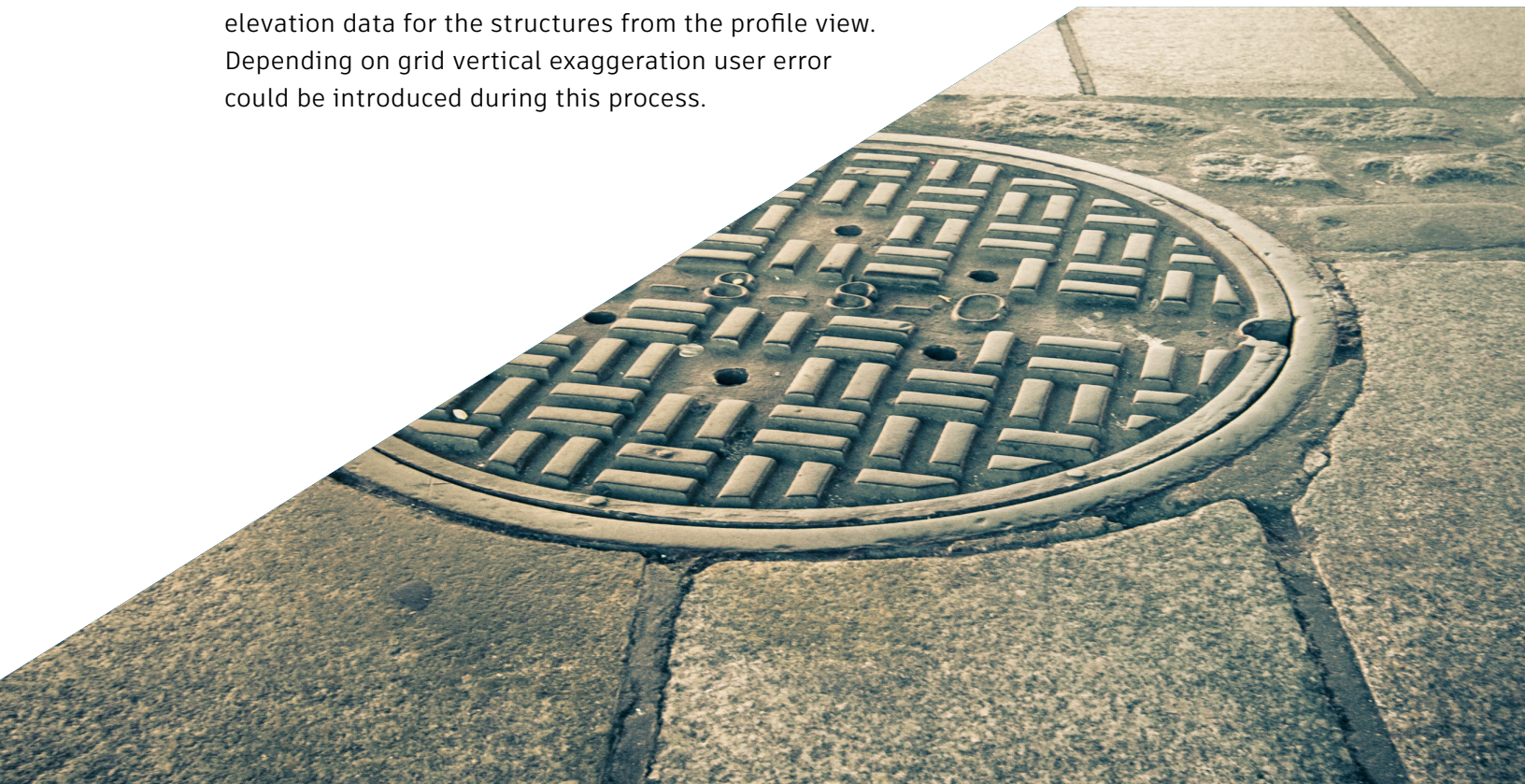

Design task 7

Automation of labeling

Labeling of pipes and structures communicates critical details about the pipe network that may not be clear otherwise.

Steps in AutoCAD

1. Edit each structure's attribute data with structure number, rim elevation, sump elevation, and outlet pipe invert elevation.
2. Create an MTEXT for each structure that includes fields that display the attribute data.

Steps in Civil 3D

1. Use Label Entire Network Plan.
2. Use Label Entire Network Profile.
3. Select and drag structure labels and pipe labels to more readable locations around the project area, and the profile view.

Steps in Civil 3D

- 44.9% speed gain when using Civil 3D.
- For the AutoCAD process, it was assumed that the structures would be represented by blocks that included attribute information. This would be part of the company standard template. This allows for data to be entered into the block for easy display in labels. This would still require manual entry of structure data in the block attributes since this data would not be updated from the network parts geometry. But this in turn would allow for the labels to update with the data stored in the block.
- Most of the time spent in Civil 3D labelling was dragging labels to a better more readable location.

Productivity gains

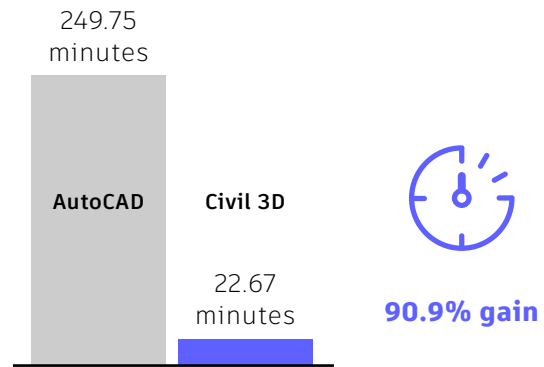

Tasks	AutoCAD	Civil 3D	Time savings using Civil 3D
1. Surface analysis for falls and catchments	8	3	62.5%
2. Network layout (horizontal & vertical)	23	6	73.9%
3. Crossing pipes clash check	24	2	91.7%
4. Drainage profile	152	2	98.7%
5. Drawing production (plans/profiles)	32	5.5	82.8%
6. Manhole schedule	5	1	80.0%
7. Automation of labeling	5.75	3.17	44.9%

(Figures shown in minutes)

Grading

This workflow includes the following tasks:

1. Parking lot grading
2. Road and highway grading
3. Subdivision grading
4. Pond grading

Design capabilities enhanced

- Site Model Authoring

Data size & scope

- 1,340 feet of graded berm
- 1,650 ft² of pond grading area
- 10,121 ft² of parking lot area grading



Design task 1

Parking lot grading

Due to sheet size and scale on those sheets the design area is limited to how much will fit on each page. The overall length of the pipe network will be displayed in multiple sheets with specified length per sheet. A profile view will be created to reflect the plan stationing from each sheet's length.

Steps in AutoCAD

1. Find the elevation where the design ties-in to the existing surface.
2. Use cross slopes to assign elevations to the corners of the proposed grading area.
3. Find elevations along edge slopes where contour lines will be created.
4. Create contour polylines through proposed grading area.

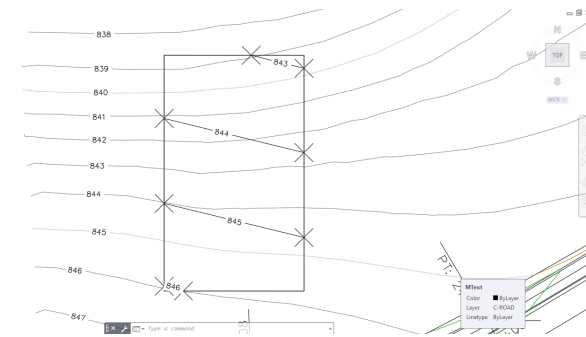

Parking lot grading layout in AutoCAD

Steps in Civil 3D

1. Create a feature line from the proposed grading area.
2. Assign existing surface elevation at tie-in location.
3. Edit feature line slopes to the cross slope and downslope settings.
4. Create a surface and add the feature line as a breakline.

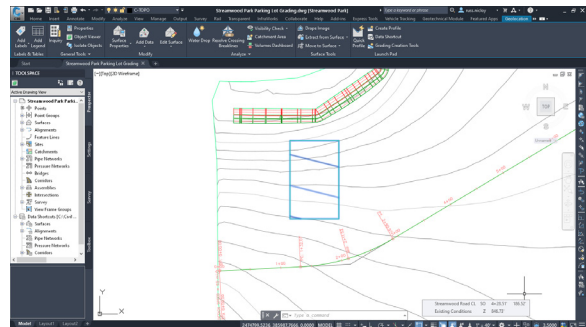

Parking lot grading layout in Civil 3D

Findings

- 90.9% time savings for parking lot grading using Civil 3D.
- This process was to find the grading surface and did not include sideslope grading. There were areas that retaining walls would have been needed and would have complicated the time calculations for the process study.

Design task 2

Road & highway grading

Grading can create a more appropriate ditch or other design needs along a roadway. Finding the location and elevations along the design gives a start point. Then slope grading to the design elevation and other resulting gradings back to the slope intercept location will complete the design.

Steps in AutoCAD

1. Offset the outside road design line the distance to the ditch offset.
2. Find the elevations at the road edge line.
3. Calculate the elevations based on slope and offset distance along the ditch bottom.
4. Create contour polylines using the elevations to estimate location and slope back up to slope intercept.

Steps in Civil 3D

1. Extract the corridor feature lines at the edge of the design.
2. Create grading from those extracted feature lines to ditch bottom.
3. Create grading from ditch bottom up to surface.

Findings

- 93.3% productivity gain using Civil 3D.
- The AutoCAD process has a lot of user estimation and rough drafting. This leads to the high probability of errors in the final design.



Design task 2

Subdivision grading

Grading that provides new surface conditions in a subdivision should be created in localized areas, such as berms or drainage swales. Starting from existing conditions slopes should be created. Then, resulting gradings that finish the design and tie-in to the existing conditions can be completed.

Steps in AutoCAD

1. Find elevations at existing surface triangles along tie-in of berm grading.
2. Draw line at known elevation points along surface triangles.
3. Create a polyline at contour elevation above the known elevation line.
4. Enter the elevation into the polyline so it is at the proper elevation.
5. Offset first contour polyline at a 5' (1.52 m) distance for each foot of rise (5:1 slope).
6. Create mtext labels for the contours.

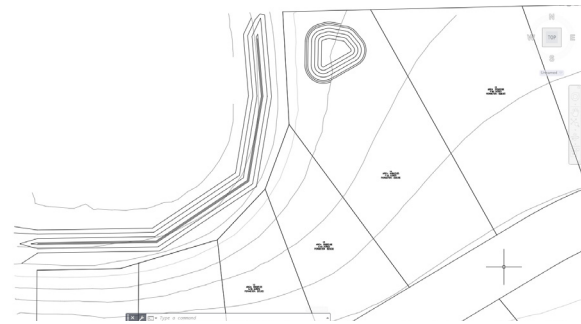

Subdivision grading in AutoCAD

Steps in Civil 3D

1. Draw feature line at location of beginning of grading.
2. Drape the feature line over the existing surface to recreate the tie-in elevations from the start of grading.
3. Grade to an elevation at slope to create the top of berm.
4. Grade a flat top for a certain distance.
5. Grade down to surface at a slope to tie-in the end of the grading.

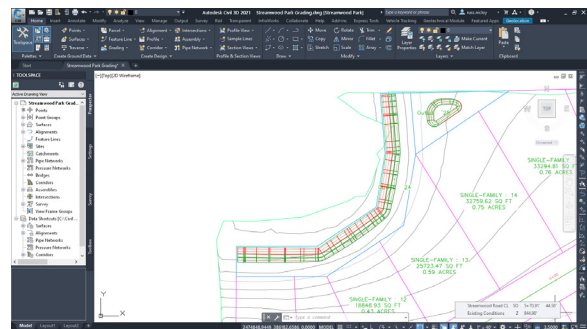

Subdivision grading in Civil 3D

Findings

- 77.5% gains using Civil 3D on this subdivision grading task.
- The AutoCAD process does require some estimation at the tie-ins leading to chances of slight loss of precision. These tie-ins would be field engineered during construction. Only the volume calculations may be affected, within a margin of error.

Design task 5

Pond grading

Pond grading will require proper slope and depth to retain the required volume of stormwater runoff. Both the pond top elevation and the elevation of the pond bottom are important to this grading and may affect the area that the pond is designed in.

Steps in AutoCAD

1. Create a polyline at the pond top (or the bottom) elevation.
2. Calculate the next contour line elevation and offset the polyline the distance to create the correct slope (example 5:1).
3. Set the elevation of that contour line to the contour elevation.
4. Offset the contour line at proper distance for each 1' (0.3 m) of elevation difference.
5. Find the pond bottom (or top) by calculating the distance offset from the last contour to the target elevation.
6. Repeat this for the elevation outside of the pond top to tie-in to the existing surface.
7. Where the contours outside the pond cross existing contours of the same elevation trim the proposed contours at the existing contours.
8. Create mtext labels for the contours.

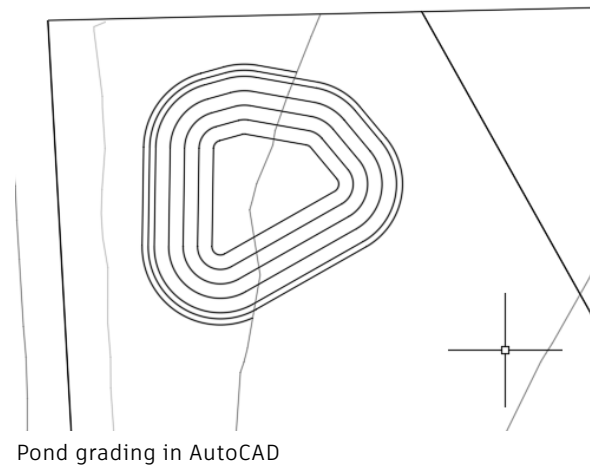

Steps in Civil 3D

1. Create a feature line at the pond top (or bottom).
2. Edit this feature line to be at the proper elevation, and fillet if smooth curved edges are desired.
3. Use the grading tools to grade to the pond bottom (or to the top).
4. Grade from the pond top to the existing surface outside of the pond to tie the pond into the existing conditions.
5. Display the surface contours to review the pond design.

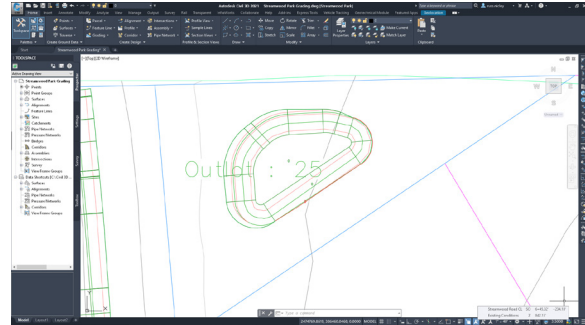

Pond grading in Civil 3D

Findings

1. 40% time savings on pond grading using Civil 3D.
2. The AutoCAD process does require some estimation at the tie-ins leading to chances of slight loss of precision. These tie-ins would be field engineered during construction. Only the volume calculations may be affected, within a margin of error.

Productivity gains

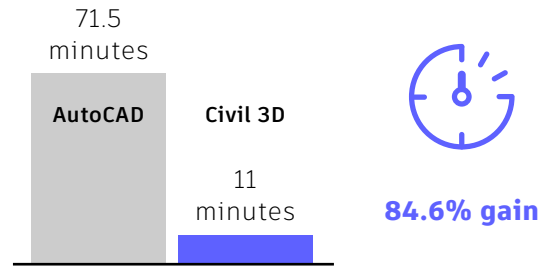

Tasks	AutoCAD	Civil 3D	Time savings using Civil 3D
1. Parking lot grading	16.5	1.5	90.9%
2. Road and highway grading	30	2	93.3%
3. Subdivision grading	20	4.5	77.5%
4. Pond grading	5	3	40.0%

(Figures shown in minutes)

Corridor modeling

This workflow includes the following tasks:

1. Sample existing ground
2. Design cross-sections
3. Build corridor
4. Sample corridor

Design capabilities enhanced

- Road and Highway Model Authoring
- Rail Track Model Authoring

Data size & scope

- 1,220 feet of corridor design
- Frequency at 10 feet (Civil 3D)
- Frequency at 100 feet (AutoCAD)
- 10,121 ft² of parking lot area grading



Design task 1

Sample existing ground

Grading that provides new surface conditions in a subdivision should be created in localized areas, such as berms or drainage swales. Starting from existing conditions slopes should be created. Then, resulting gradings that finish the design and tie-in to the existing conditions can be completed.

Steps in AutoCAD

1. Draw a line perpendicular to the alignment at every 100' station. Make this line 75 feet (22.86 m) to either side of the alignment.
2. Where this line crosses a surface triangle, place a point on the triangle to capture the elevation.
3. Create a section view grid with enough height for the elevation difference.
4. Copy the section view grid for each of the sample lines.
5. For the first sample line, find the elevation of the first point, and measure the distance from the centerline.
6. Place a point in the section view at this offset and at this elevation.
7. Continue finding the elevation and offset of each point along the sample line and translating them into the section view grid.
8. Repeat this process for each sample line and section view.

Steps in Civil 3D

1. Create sample lines attached to the road centerline alignment.
2. Create sample lines at 100' intervals with 75' (22.86 m) on either side of the alignment.
3. Create multiple section views from these sample lines.

Findings

- 99.9% time savings using Civil 3D to sample existing conditions.
- The AutoCAD process requires many transfers of numbers and locations. These steps add the likelihood of errors in calculation or transposing numbers.
- The Civil 3D process does not need the existing conditions sampled prior to creating the corridor road design. It was completed at this step, in case it is desired prior to the corridor creation.

Design task 2

Sample existing ground

The design cross section will provide data about where the road design will be located in relation to the alignment and profile along the project. The cross section may be created with a vertical exaggeration to better display details of the design.

Steps in AutoCAD

- Draw a line to represent the center of the design.
- Offset that line for the distances of the widths.
 - Lane 15' (4.57 m), gutter pan 2' (0.61 m), gutter top 0.5' (0.15 m), terrace 5' (1.52 m), sidewalk 5' (1.52 m), outside terrace 1' (0.3 m).
- Draw a line horizontally from the centerline for the distance of the lane width. In this case 15' (4.57 m) wide.
- Draw a vertical line down to capture the elevation change of the lane over that distance. In this case $(15' * 0.02) * 10 = 3$. (multiplied by 10 for the vertical exaggeration).
 - From these two measurements create the top of the lane. Delete the horizontal and vertical lines, leaving the lane slope line.
- From the end of the pavement line draw a horizontal line for the width of the gutter pan (2' or 0.61 m) and then a vertical line for the depth to the gutter flow line. In this case $(2' * 0.02) * 10 = 0.4$. (multiplied by 10 for the vertical exaggeration).
 - From these two measurements create the top of the gutter pan. Delete the horizontal and vertical lines, leaving the gutter pan slope line.

- Continue drawing the top of the design across the curb and gutter, the inside terrace and sidewalk and outside terrace at +2%.
- Offset down the lane top line, the pan top line and the sidewalk line to create the depths of materials in those areas (including the 10-vertical exaggeration).
- Continue to offset, draw, trim, and extend to finish the design cross section.
- Mirror the right-side design to the left to finish the complete design cross section.

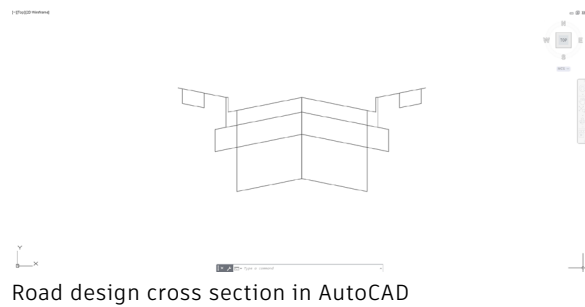

Road design cross section in AutoCAD

Steps in Civil 3D

1. Place an assembly object.
2. Open the tool palette to access the subassembly tools.
3. Place a lane subassembly at the assembly marker.
4. Place a curb and gutter, sidewalk, and daylight subassembly to the assembly.
5. Use the Subassembly Mirror tool to copy the right-side subassemblies to the left of the assembly.
6. Place the Daylight General subassembly to both sides of the assembly. Change the daylight slope to 6:1.

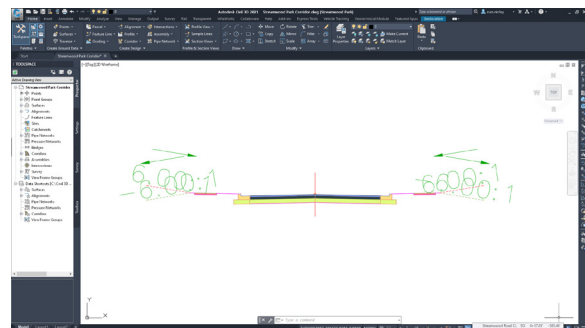

Road cross section Assembly in Civil 3D

Steps in Civil 3D

- 85% gain when using Civil 3D on this cross section design task.
- The Civil 3D cross section assembly does not require the vertical exaggeration.

Design task 3

Build corridor

Apply the design cross section into each section view grid at the elevation specified by the proposed profile. This will identify the cross-sectional shape of the corridor, further defining the horizontal design edgelines and elevation locations.

Steps in AutoCAD

1. Copy the design cross section into each section view grid at the elevation specified by the proposed profile at that station.
2. In each section draw a line from the end of the design cross section horizontally 6' (1.82 m) then vertically 10' (3.04 m) down (to match the 10-vertical exaggeration). This identifies the 6:1 slope (with 10 vertical exaggeration).
3. Draw the slope line from the design edge to the end of the horizontal and vertical construction lines. Trim the slope line where it contacts the existing ground line. Delete the horizontal and vertical construction lines.
4. Offset the alignment line to the width of the lane, gutter pan, curb top, inside terrace, sidewalk, and outside terrace locations on both sides of the alignment.
5. At each sample line mark the offset distance to where the daylight slope line intersects with the existing ground in the section view. Repeat this for both sides of the road design at each sample line.
6. Draw a polyline from daylight point on sample to the daylight point on the next sample line. At curves in the road estimate the arc curve of that daylight line to maintain the transition to the next sample line.

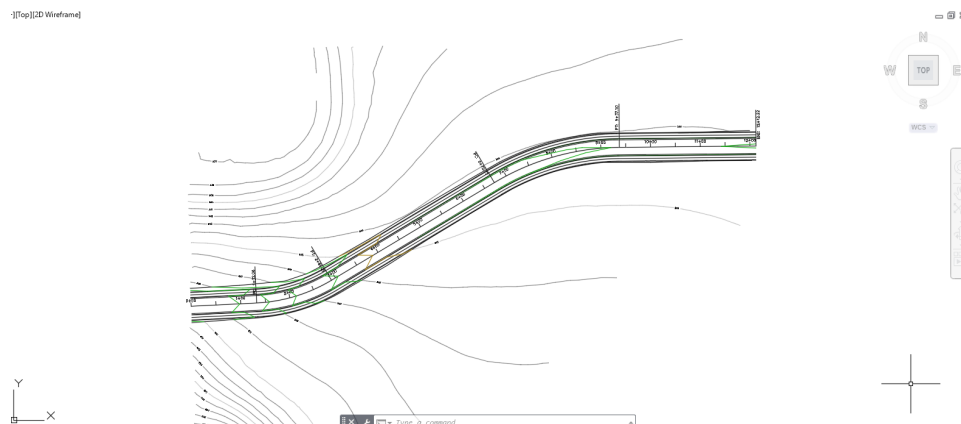

Road design in AutoCAD

Steps in Civil 3D

1. Create the corridor object.
2. Assign the alignment, profile, and cross section assembly.
3. Target the existing ground for the daylight subassemblies.

“In the AutoCAD process, you are not building a 3D corridor roadway object.”

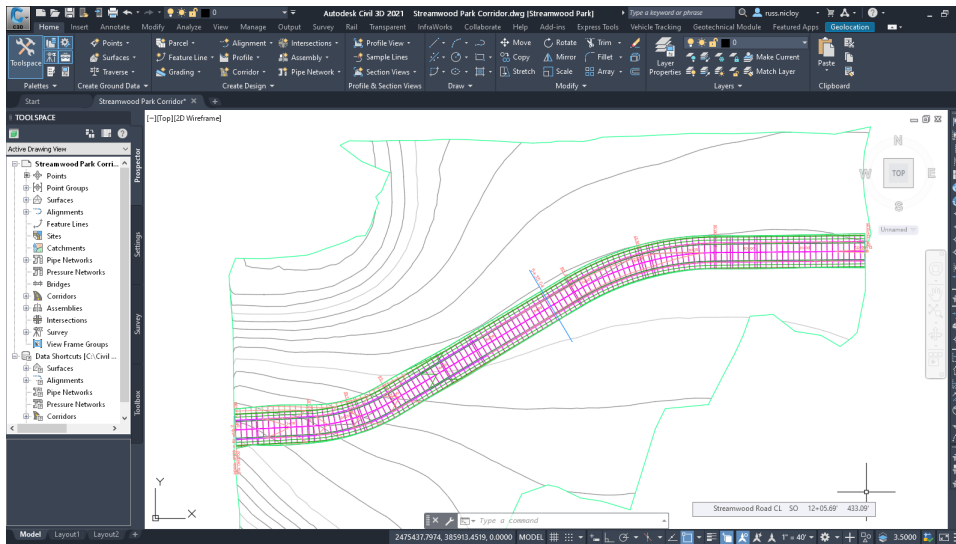

Corridor design in Civil 3D

Findings

- 86.5% time savings using Civil 3D.
- In the AutoCAD process, you are not building a 3D corridor roadway object. You are laying out the horizontal locations of the edgelines along the road design. You are also identifying where the slope intercept line (daylight line) is located at each design cross section.
- In both cases accuracy in the slope intercept (daylight line) location, as well as other design locations, will be increased with more frequencies of the design cross section. In the AutoCAD process this would increase the time proportionally. The Civil 3D process a change to the corridor frequency number would accomplish this.

Design task 4

Sample corridor

After the road design is completed, it may be recommended to spot check the design by sampling the corridor.

Steps in AutoCAD

1. Draw a line perpendicular to the alignment across the road design
2. Create a section view grid the width of the sample line.
3. Copy the design cross section into the section view grid at the elevation specified by the proposed profile at that station.
4. In the section calculate and draw a slope line from the end of the design cross section at 6:1 slope (with 10 vertical exaggeration). Trim the slope line where it contacts the existing ground line. Repeat for the other side of the section view.

Steps in Civil 3D

1. Create a sample line at a station along the design alignment.
2. Sample the corridor and existing ground data.
3. Create a section view to display the corridor and existing ground at that station.

Findings

- 66.7% time savings using Civil 3D to conduct this corridor sampling task.
- The Civil 3D process allows you to move the sample line and watch the changes in the section view at different stations. That AutoCAD process will need to be recreated at any station a cross section is needed at.

Productivity gains

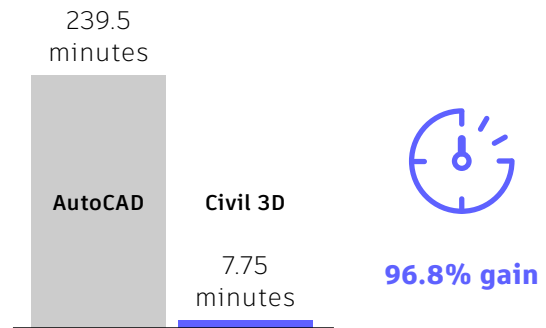

Tasks	AutoCAD	Civil 3D	Time savings using Civil 3D
1. Sample existing ground	195	0.25	99.9%
2. Design cross-sections	20	3	85.0%
3. Build corridor	18.5	2.5	86.5%
4. Sample corridor	6	2	66.7%

(Figures shown in minutes)

Drawing production

This workflow includes the following tasks:

1. Sheet layout
2. Plan and profile sheet production
3. Cut section sheets
4. Labels relative to sheet
5. Updates and edits
6. Drawing standards

Design capabilities enhanced

- Digital Drafting
- Documentationrack Model Authoring

Data size & scope

- Number of sheets: 3 plan
profile, 8 cross sections
- Total 1220 feet, 580 feet per sheet
- Cross section sample lines every 50 feet (no special stations, like horizontal/vertical geometry, super elevation, etc.)

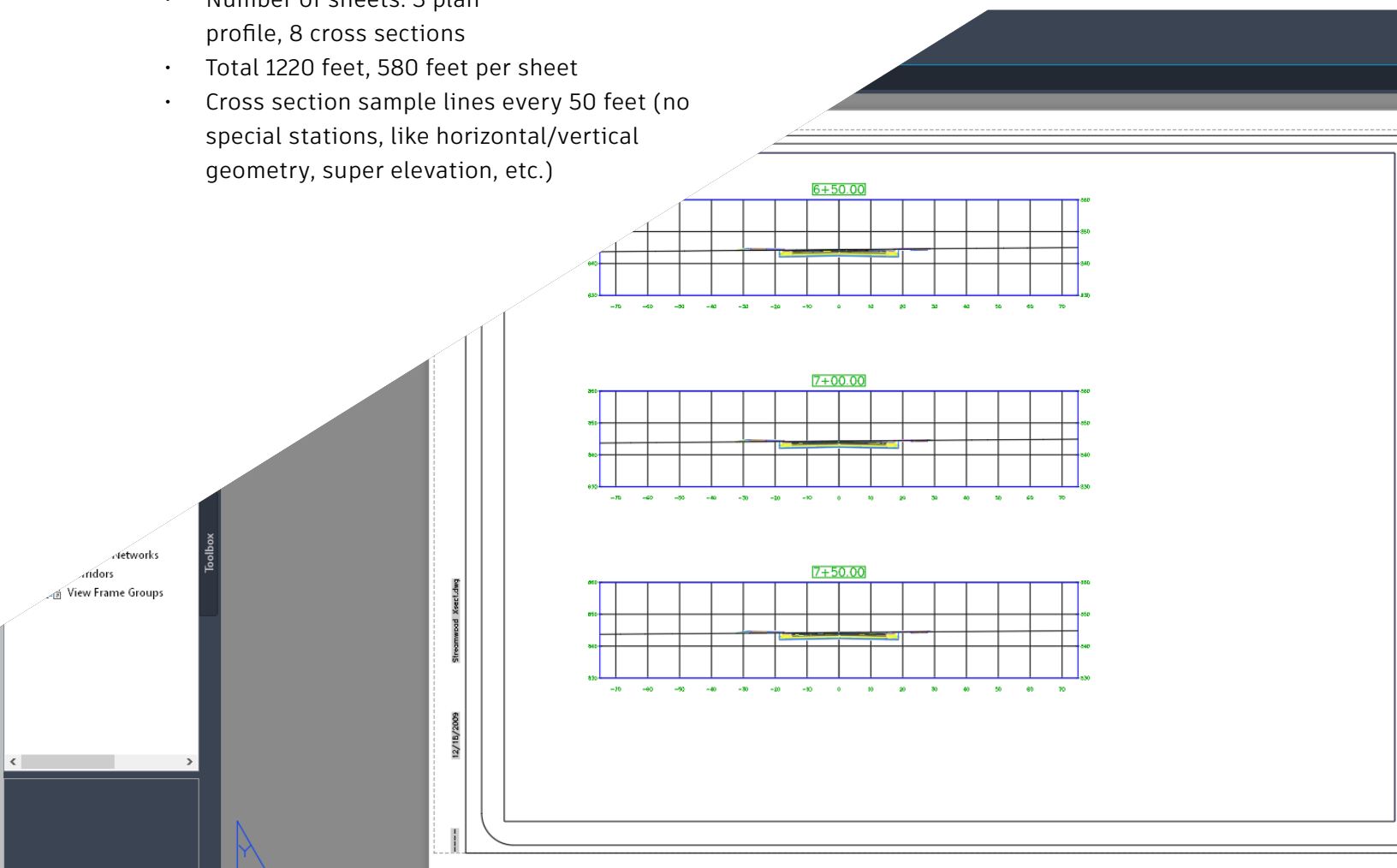

Design task 1

Sheet layout

When creating the sheets for plan sheet production there will be limited paper space to fit the length of the project. In the layout tab having the page size and title block set will show how much space is available for displaying the design and what scale would maximize that space. Inserting the existing conditions and the design you can then measure how much can be displayed on a sheet.

Steps in AutoCAD

1. Copy the existing surface contours and proposed project design.
2. Paste the existing contours and proposed design into the drawing file used for sheet creation.
3. Switch to the layout tab, unlock the top viewport and zoom to it. Set the scale and rotate it so the project design fits best on the page. Lock the viewport to preserve this rotation and scale.
4. Estimate how much alignment stationing fits inside the view.

Steps in Civil 3D

1. Data shortcut reference existing surface, proposed alignment and profile, and the corridor for the design.
2. Switch to the layout tab, unlock the top viewport and zoom to it. Set the scale and rotate it so the project design fits best on the page. Lock the viewport to preserve this rotation and scale.
3. Estimate how much alignment stationing fits on the page.

Findings

- 80% time savings on sheet layout tasks using Civil 3D.
- The AutoCAD process requires copying the data into another file so as not to add plan and profile sheets to the design file, and so the profile views can be split into sheet-sized grids. This creates an unlinked version of the data. If changes take place in the design file, the user must manually update (repeat the copy/paste) the sheet file. This has a potential for missed or incorrect updating.

Design task 2

Plan-profile sheet production

In the sheet set produced for the project, a series of sheets that display an amount of the plan view and the corresponding length of profile view will be made. These are important for indexing horizontal and vertical design for construction.

Steps in AutoCAD

1. Copy the layout tab that was created in the Sheet Layout task above, once for each sheet expected in the plan and profile sheets.
2. Unlock and adjust the plan view viewport over each section of alignment that will fit into the scaled viewport. This may require some rotation to make the views fit properly.
3. Take the profile view that was copied into the file during the Sheet Layout task above and make a copy for each expected viewport.
4. Trim each profile view to the stations represented in the plan view layout tabs. Move text and shorten the elevations (if needed) to fit the scaled viewports.
5. In each layout tab adjust the profile viewports over the newly trimmed profile views. This may require adjustments to the profile grid and related station and elevation text.

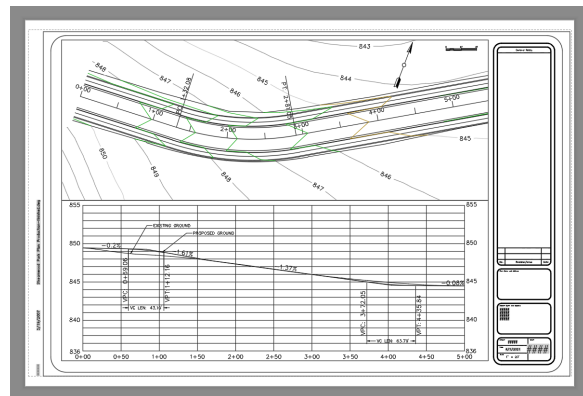

Plan over profile sheet in AutoCAD

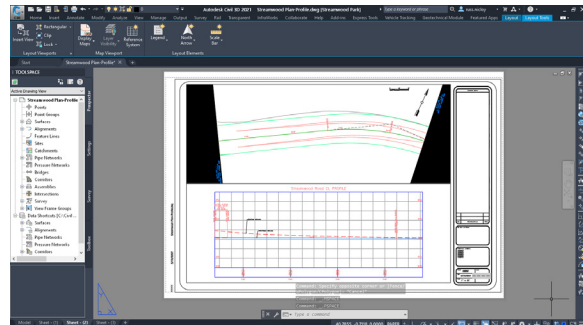

Plan over profile sheet in Civil 3D

Steps in AutoCAD

1. Data shortcut reference the design alignment, profile, and corridor into the sheet view file.
2. Create view frames along the design alignment.
3. Create Sheets command.

Findings

- 82.8% productivity gain on plan-profile sheet production using Civil 3D.
- In the AutoCAD process creating the extra copies of the profile views essentially creates more unlinked data. When design changes and revisions take place this file and these views need to be updated manually. This creates a potential for missed or incorrect updating.

Design task 3

Cut section sheets

The cut section sheets display section views in station order for the construction team to check the design along the project. These sheets usually hold more than one view per sheet, depending on depth at each station shown.

Steps in AutoCAD

1. Copy the section views from the design file (as long as they are up to date with the design) and paste them into the plan production sheet file.
2. Arrange them so several views will fit in a sheet layout viewport. Trim and adjust as necessary.
3. In the sheet view layout tabs center the viewport over the first set of views and make sure the scale is correctly set. Lock the viewport.
4. Repeat this process for each layout sheet needed to display all the provided section views.

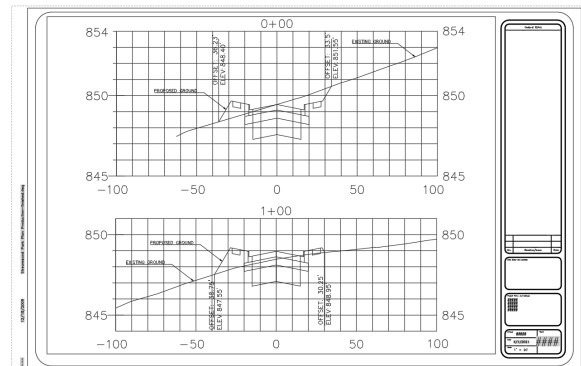

Cross section sheet in AutoCAD

Steps in Civil 3D

1. Data shortcut reference the design alignment, profile, and corridor into the sheet view file.
2. Set the file to the proper scale to array the section views properly.
3. Create sample lines along the design alignment.
4. Create multiple section views.
5. Use the Create Section Sheet command and identify the section views that were just placed.
6. Review the sheet layout tabs that were created.

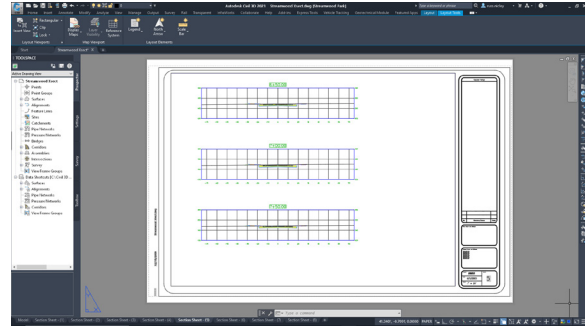

Cross section sheet in Civil 3D

Findings

- 85.4% time savings using Civil 3D.
- The AutoCAD process requires copying the data into another file so as not to add cross section sheets to the design file. This creates an unlinked version of the data. If changes take place in the design file, the user must go and manually update (repeat the copy/paste) the sheet file. This has a potential for missed or incorrect updating.

Design task 4

Labels relative to sheet

There are labels that need to be added to plan profile and section sheets to indicate what the user is showing. These labels are beyond the alignment and profile labels, so generally will be manually placed.

Steps in AutoCAD

1. Add mtext with an annotative text style to contour labels over surface contours.
2. Calculate and add profile slope labels where necessary.
3. Add curve labels to include start, end, and length of curve stations.
4. Place offset labels at break points in each section view.
5. Place “existing ground” and “proposed ground” labels in each section view and profile view.
6. Place and rotate the north arrow to indicate plan view sheet rotation.

Steps in AutoCAD

1. Place “existing ground” and “proposed ground” labels in each section view and profile view.
2. Place and rotate the north arrow to indicate plan view sheet rotation.

Findings

1. 93.5% efficiency gain when using Civil 3D.
2. The AutoCAD process requires much manual data input increasing chances for error.
3. Civil 3D labels for objects such as alignment tangents and curves, and section view offset points are all done automatically. No special step to place these is necessary.

Design task 5

Updates and edits

Projects inevitably require revisions and changes. As a design is reviewed, design requirements may be found to be outside of code or other options pursued, forcing changes which need to be represented in the design. Further review cycles may create additional revision changes. For this study, the revision to the project was to move the west entrance into the development 50' (15.24 m) to the south.

Steps in AutoCAD

1. Alignment recreation.
2. New alignment labeling.
3. Existing profile recreation at new alignment location.
4. Proposed profile recreation/adjustment.
5. Pipe adjustment to new locations.
6. Pipe network structures and pipes recreated in profile view.
7. New pipe and structure labels.
8. Corridor modeling
9. Resample existing conditions.
10. Recreate slope intercept/daylight locations.
11. Recreate corridor edgeline offsets.

Steps in AutoCAD

1. Move the alignment.
2. Adjust the proposed profile relative to the new existing profile.
3. Rebuild the corridor.
4. Synchronize plan/profile and section sheet layout drawing file.
5. Make adjustments to labels in plan/profile and section sheet views.

Findings

- 97.4% time savings when using Civil 3D to make needed updates and edits.
- For the AutoCAD process, while the revision to the project may be small, it required recreation of some of the design elements due to cascading effect. An example would be a small change in the bearing or distance of an alignment affecting the location and the stationing of the rest of the alignment from that point to the end. This also effects profile views and where things like design sections were sampled, among other time-consuming processes.
- For the AutoCAD process, changes to the design file need to be reflected in the plan/profile and section view sheets.

Design task 6

Drawing standards

Maintaining drawing standards start with using the correct template file. A template file will start a drawing file with the proper layers, linetypes, text styles, among other settings. A Civil 3D template also brings a list of settings object styles, labels styles, and table styles, along with standardized command settings. These all help in maintaining the look and readability of a design set, but also helps speed the development of the design files.

Steps in AutoCAD

1. From the Menu Browser choose New.
2. Select the template to use to start the file.
3. Save the file with its design name in a project folder.

Steps in Civil3D

1. From the Menu Browser choose New.
2. Select the template to use to start the file.
3. Save the file with its design name in a project folder.

Findings

- While the time to start a file was generally the same for both AutoCAD and Civil 3D, the Civil 3D design files have much more standardized data and workflow steps meaning time is saved from this step throughout the project design process.
- In both the AutoCAD process and Civil 3D process use of the QNEW assigned to an organizational template file will speed this process even more. The organization's template can be stored anywhere, and one click will retrieve it reducing browsing to find it.

Productivity gains

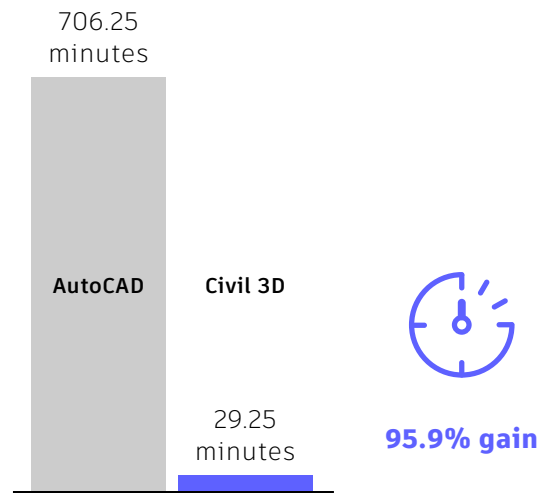

Tasks	AutoCAD	Civil 3D	Time savings using Civil 3D
1. Sheet layout	5	1	80.0%
2. Plan and profile sheet production	32	5.5	82.8%
3. Cut section sheets	24	3.5	85.4%
4. Labels relative to sheet	62	4	93.5%
5. Update and edit	583	15	97.4%
6. Drawing standards	0.25	0.25	0.0%

(Figures shown in minutes)

Quantity takeoff

This workflow includes the following tasks:

1. Item counts
2. Item distances
3. Item areas
4. Compared surfaces (volumetric)

Design capabilities enhanced

- Quantification and Scheduling

Data size & scope

- 16 manholes
- 2,400 feet of clearing and grubbing
- Area identified: 3.4 acres
- Earthwork only: 2D area – 708,004 ft², cut 537 yd³, 1,013 yd³, net: 477 yd³ fill

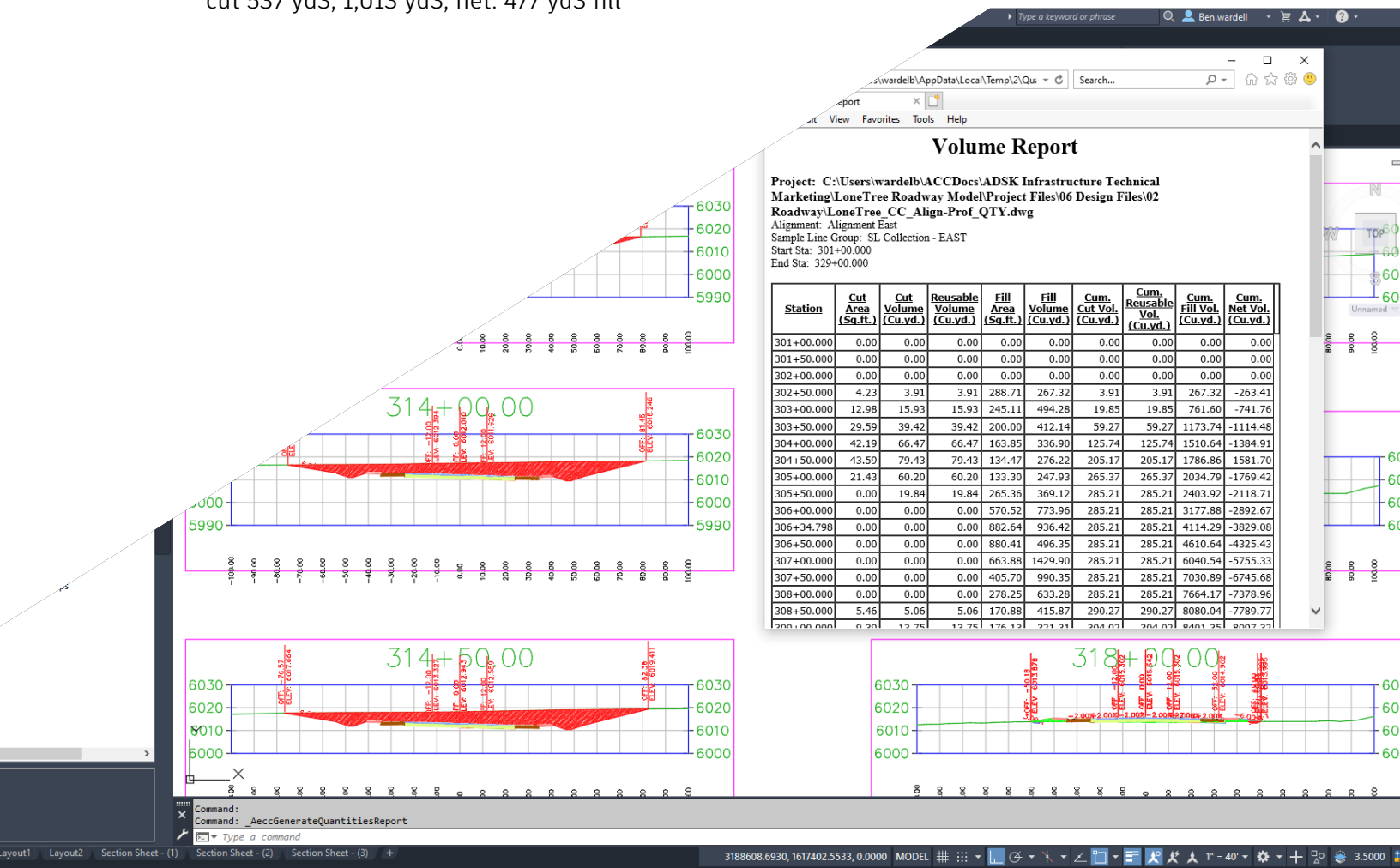

Design task 1

Counts of items

It is important to track the counts of items for things like manholes or light poles along a project. This process could be simple counting of objects, but the possibility of missing an object is high. Automating the counting process may require some earlier standardized setup. In AutoCAD this would mean use of blocks for objects that will be counted. In Civil 3D it means having a Pay Item tool setup with standard quantities in place.

Steps in AutoCAD

1. Previous to running the Data Extraction tool, the block attributes were added to the pipe network structure blocks, including the TYPE field.
2. Run the Data Extraction tool.
3. Change the filters to be for Display Blocks Only, and Display Blocks with Attributes Only.
4. Change the Blocks filters to only return Attribute data.
5. Turn off all attributes except TYPE. The Data Extraction tool will separate any unique data and only the TYPE has the count information that is needed here.
6. Create a table in the drawing file (or output to a CSV file).
7. The output holds the counts.

Steps in Civil3D

1. Open QTO (pay item tool)
2. Expand proper pay item area and select the pay item.
3. Assign to objects.
4. Run pay item report.

Steps in Civil3D

- 2.5x longer to perform this counts of items task when using Civil 3D compared to base AutoCAD.
- This time calculation is for an initial run for Civil 3D pay items which included initial setup for this project. After the initial run, subsequent runs are much faster.

Design task 2

Areas

It is important to calculate the areas of items for cost items that are based on area, like clearing and grubbing, or seeding and staking. This data is calculated into the cost of the project prior to construction.

Steps in AutoCAD

1. Draw a closed polyline shape around the area to calculate.
2. Open the Properties palette.
3. Select the closed polyline shape and find the Area field.
4. Enter that area number into a CSV file or a table in the design file.

Steps in Civil 3D

1. Draw closed polyline areas to be calculated.
2. Open QTO pay item list.
3. Expand and select the pay item.
4. Assign to the closed polyline areas.
5. Run pay item report.

Findings

- 3x additional time is needed to complete area calculations using Civil 3D vs. base AutoCAD.
- This time calculation is for an initial run for Civil 3D pay items which included initial setup for this project. After the initial run, subsequent runs are much faster.



Design task 4

Compare surfaces (volumetric)

It is important to be able to quantify how much earthwork is being added or removed from the project design area. Comparing the subgrade surface to the existing conditions will provide the volume of dirt that will need to be transported in or out of the project.

Steps in AutoCAD

1. Use contour volume method
 - Find proposed contour and existing contour of same elevation. If they cross break so they meet at a point.
 - AutoCAD AREA measurement, Add by Object. Select the proposed contour. This will measure area between proposed and existing.
 - AutoCAD AREA measurement, Add by Object, to measure amount to subtract.
 - Take difference from each contour (existing vs proposed) and add together, divide by 2 (to take average) then multiply by the elevation difference.

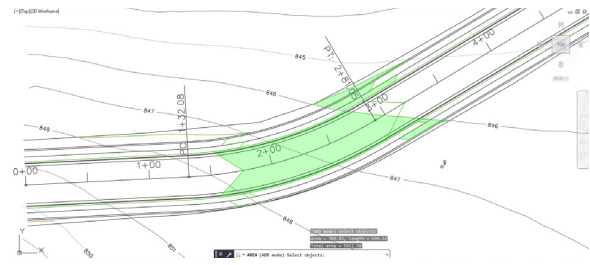

Volume calculation by contour area difference.

Steps in AutoCAD

- Open the Volume Dashboard
- Create a volume surface object in the Volume Dashboard.
- Assign the existing and the corridor datum surface to that volume surface entry.
- Review volume calculation in volume surface Volume Dashboard grid.

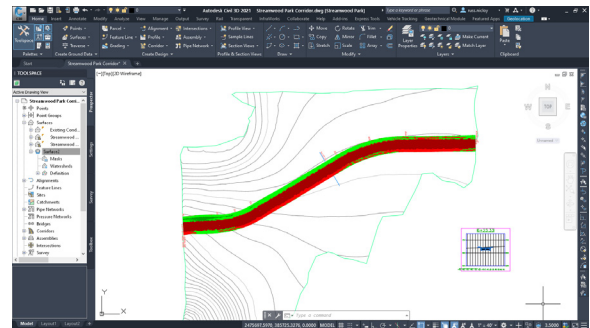

Civil 3D volume calculation cut/fill map.

Findings

- 78.6% time savings using Civil 3D.
- The Civil 3D process using the Volume Dashboard could be replaced by creating a volume surface and checking the surface properties – Statistics tab. The amount of time for either process would be similar, and the choice of which to use would simply depend on user preference.
- For the AutoCAD process, the more contour intervals the closer this calculation will be. Due to the time-intensive contour creation process there should be a balance between contour creation and preferred accuracy in volume calculation.

Productivity gains

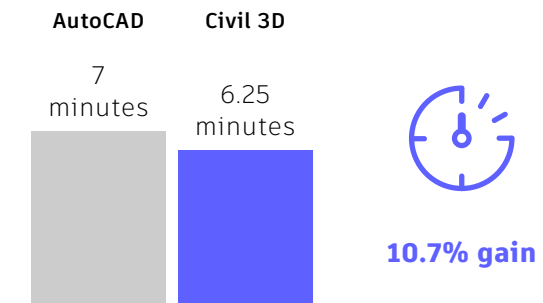

Tasks	AutoCAD	Civil 3D	Time savings using Civil 3D
1. Item counts	1	2.5	-150.0%
2. Item distances	2	1.5	25.0%
3. Item areas	0.5	1.5	-200.0%
4. Compare surfaces (volumetrics)	3.5	0.75	78.6%

(Figures shown in minutes)

Schedules production

This workflow includes the following tasks:

1. Table creation
2. Data acquisition for the table
3. Updates and edits
4. Custom styles per data type

Design capabilities enhanced

- Quantification and Scheduling

Data size & scope

- 12 structures in schedule (manholes, inlets, and flared end sections)
- 15 pipes: 12", 15", 18", 30" and 36" RCP pipes.
Total length = 1,340 feet



Design task 1

Table creation

Many of the needed data counts will need to be displayed in a table form inside the design file for quick access. Tables can be quickly created and customized for the type of data that needs to be displayed.

Steps in AutoCAD

1. Start the Table command.
2. Identify the style of table, and how many rows and columns are needed.
3. Place the table in the file.
4. Enter the title cell information.
5. Enter the column header information.

Steps in Civil 3D

1. In the Annotation ribbon select Add Tables and select the type of object the table will display for.
2. During the creation process you will identify the objects that will be placed in the table.
3. Place the table in the design file.

Findings

- 34% faster in table creation tasks using Civil 3D.
- Since the Civil 3D process of table creation also populates the table with data this makes the process more efficient. Extra time will be saved in the next tasks of the study.

Design task 2

Data acquisition for the table

Many of the needed data counts will need to be displayed in a table form inside the design file for quick access. Tables can be quickly created and customized for the type of data that needs to be displayed.

Steps in AutoCAD

1. Manually enter the data into the fields of the table.

Steps in Civil 3D

1. This process is completed during the table creation.

Findings

- The Civil 3D process of acquiring the data for the table is completed automatically while creating the table in the task above (Table Creation).
- In the AutoCAD process you could add object data fields to the table cells. While this process would take slightly longer than the manual data entry, it will add some level of dynamic connection between design objects and the table entries.
- The AutoCAD process is dependent on user entry which could lead to typographic errors.

Design task 3

Updates and edits

In the case of revisions or changes table information will need to be updated.

Steps in AutoCAD

1. Manually update the table fields to reflect updates in the design file.

Steps in Civil 3D

1. The tables will update automatically when an object is updated.

Findings

- The AutoCAD process could be faster if earlier object fields were put into the table fields. This would make the table creation slightly longer but make the update process faster.
- In this case manual re-entry was chosen. Due to the retyping of information this could add errors to the tables.

Design task 3

Custom styles per data type

To ensure the tables are providing the object data that need to be viewed some tables may need to be customized. These customizations can be added to the settings of the drawing file where they are or added to the template, so they become available as part of the organization's standard drawing files.

Steps in AutoCAD

1. Create a table.
2. Enter the title and header information as will be needed in future uses.
3. Save the table style.

Steps in Civil 3D

1. Edit the object table style.
2. Delete columns that are not needed.
3. Add columns that are needed.
4. Add header information and formatting for the new fields.
5. Move the columns so they are in a correct order.

Findings

- 7x more time to customize table styles using Civil 3D versus base AutoCAD.
- The Civil 3D process was slower due to more options to be adjusted. This does not reflect the time savings that the dynamic data in the table will provide. The time savings from the changes will make this a more efficient option in the long run.

Productivity gains

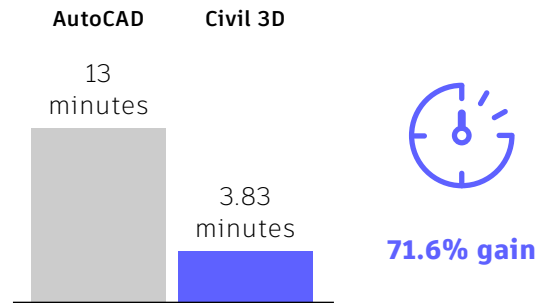

Tasks	AutoCAD	Civil 3D	Time savings using Civil 3D
1. Table creation	0.5	0.33	34.0%
2. Data acquisition for the table	9	0	100%
3. Updates and edits	3.5	0	100%
4. Custom styles per data type	0.5	3.5	600%

(Figures shown in minutes)

Design review and coordination

This workflow includes the following tasks:

1. Clash detection
2. Markups
3. Data shortcuts
4. External References (XREFs)
5. Revising design
6. Annotation updates

Design capabilities enhanced

- Design Coordination and Review

Data size & scope

- 10 design files
- 12 sheets in review packet

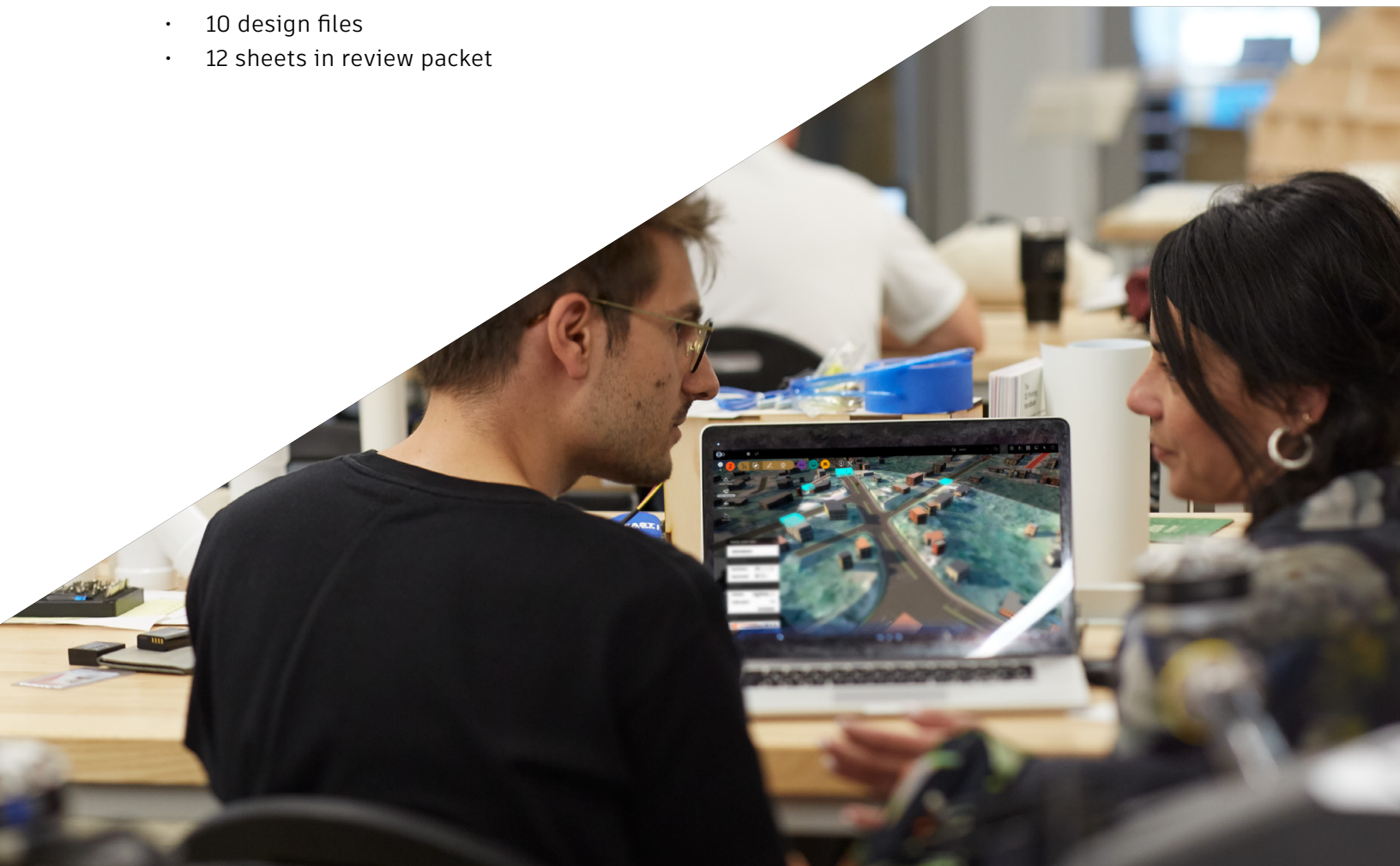

Design task 1

Clash detection

To ensure the tables are providing the object data that need to be viewed some tables may need to be customized. These customizations can be added to the settings of the drawing file where they are or added to the template, so they become available as part of the organization's standard drawing files.

Steps in AutoCAD

1. Draw a line at the location of the suspected conflict.
2. Create a section view of the line location.
3. Place a copy of the road design at the profile elevation at the station of the sample line.
4. Draw the existing pipe that is crossing the section view.
5. Draw the proposed pipe that is crossing the section view.
6. Identify any clashes between existing conditions and proposed construction.

Steps in Civil 3D

1. Create sample line at suspected conflict location. Sample surfaces, corridor, and pipes in that location.
 - You can create multiple sample locations from the same sample line group.
 - Create section views for any sample lines created.
 - Identify any clashes at these locations.

Findings

- 93.7% time savings on clash detection tasks using Civil 3D.
- The C3D sample lines can be moved along the alignment and the section view will update in the new location. In this way you could check a series of suspected locations quickly.

Design task 1

Mark-ups

After the sheets are created those tasked with reviewing may need to communicate areas of concern or other changes. Markups can take the form of leadered text with revision clouds. The sheets can be shared for review and markup from project stakeholders even if they do not have AutoCAD or Civil 3D using the Shared Views tool and an internet browser.

Steps in AutoCAD

1. Collaborate tab > Shared Views.
Create Shared Views
2. Set to 2D only, and Model and All Layouts
3. Refresh Shared Views palette.
4. From ellipsis button choose
View in Browser
5. Select a section tab.
6. Use Markup to add revision
clouds, arrows, and text.
7. Save, then close the web browser.
8. In C3D Shared Views palette
click Refresh button.
9. Click comments. This opens in the
Viewer to read the comments.
10. Close the Viewer.
11. Reply to comments.

Steps in Civil 3D

1. Collaborate tab > Shared Views.
Create Shared Views
2. Set to 2D only, and Model and All Layouts
3. Refresh Shared Views palette.
4. From ellipsis button choose
View in Browser
5. Select a section tab.
6. Use Markup to add revision
clouds, arrows, and text.
7. Save, then close the web browser.
8. In C3D Shared Views palette
click Refresh button.
9. Click comments. This opens in the
Viewer to read the comments.
10. Close the Viewer.
11. Reply to comments.

Findings

- This process is essentially the same for both AutoCAD and Civil 3D.
- The Civil 3D Shared View can include 3D design elements so reviewers can orbit the project design. While this is available in the AutoCAD version, much of the AutoCAD design is 2D where Civil 3D is inherently 3D.
- There are options that may have been used differently between the AutoCAD and Civil 3D process. For testing purposes, we kept these options consistent.
- The calculated time to complete included creating the shared view, posting it for the reviewer's access, the reviewer's (one) comment and reposting, and the user's response. This is the full round-trip time with no delays in user access to their computers.

Design task 3

Data shortcuts

Data shortcuts are a tool that allows certain Civil 3D objects that have their definition updated to share the new definition in other files. This tool makes it possible for multiple users to work on the same project, or for the project to be divided into different drawing files for sheet creation or more efficient design files.

 AutoCAD does not have a similar function.

Steps in Civil 3D

1. Set working folder for the project.
2. Create the project data folder.
3. Save file that has the definition of the object to be shared.
4. Create the data shortcuts from that file.
5. Create reference of the data shortcut in the file that requires the reference.

Findings

- There is no equivalent data shortcut referencing of data for the AutoCAD process. The choices for referencing data would be external reference (XREF) or inserting directly into a file. While the XREF process would provide updates of graphic representation, but there would be design elements that would not be updating with the project.

Design task 4

External references (XREFs)

External references (XREF) allow files to be referenced into another file to provide context in the design file.

Steps in AutoCAD

1. Use the Attach Reference command.
2. Assign the origin of the xref location, scale, and rotation.

Steps in Civil 3D

1. Use the Attach Reference command.
2. Assign the origin of the xref location, the scale and rotation.

Findings

- The process for XREFing information into a file is the same for AutoCAD as it is for Civil 3D.

Design task 5

Revising design

It is very common for revisions to be made to a project design. It is important to be able to quickly revise the project design so potential concerns or conflicts can be identified.

Steps in AutoCAD

1. Recreate the alignment.
2. Recreate the existing and proposed profile.
3. Recreate the sample lines and section views to prepare for the corridor redesign.
4. Recreate the corridor design.
5. Recreate pavement edges and slope intercept (daylight) locations.
6. Recreate the proposed contours for the design surface.

Steps in Civil 3D

1. Make the required alignment change.
2. Make sure the proposed profile is changed to reflect the new project location.
3. Make sure that the corridor is rebuilt.
4. Adjust the sheet plan views and make sure any changes to the sheet profile views are updated.

Findings

- 97.3% productivity gain when using Civil 3D for design revision tasks.
- The AutoCAD process requires nearly an entire redesign of the project. Small changes may affect the alignment stationing, profile elevations, location or depths of pipe networks, and cross section data.

Design task 6

Revising design

After revisions it is important to check that labels and annotations have updated to reflect new data. Also, the labels may need to be moved to better indicate the object they are annotating.

Steps in AutoCAD

1. REGENALL to make sure mtext field text has updated.
2. Move labels to proper locations.
3. Update any text for objects that have changed.

Steps in Civil 3D

1. Object labels will all update automatically.

Findings

- The Civil 3D labels update automatically with the objects.
- The labels changed in the AutoCAD test were spot elevation labels, slope labels, and contour labels, all local to a small change in the surface. Larger changes would require more time to complete.



Productivity gains

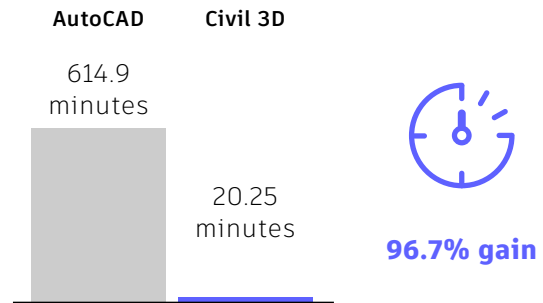

Tasks	AutoCAD	Civil 3D	Time savings using Civil 3D
1. Clash detection	37	2.33	93.7%
2. Markups	2.67	2.67	0.0%
3. Data shortcuts	0	0	0.0%
4. External references (XREFs)	0.25	0.25	0.0%
5. Revising designs	555	15	97.3%
6. Annotation updates	20	0	100%

(Figures shown in minutes)



Autodesk, the Autodesk logo, Civil 3D, the Civil 3D logo, and InfraWorks are registered trademarks or trademarks of Autodesk, Inc., and/or its subsidiaries and/or affiliates in the USA and/or other countries. All other brand names, product names, or trademarks belong to their respective holders. Autodesk reserves the right to alter product and services offerings, and specifications and pricing at any time without notice, and is not responsible for typographical or graphical errors that may appear in this document.

© 2024 Autodesk, Inc. All rights reserved.